

Service Parts Information

Model 24 Winch

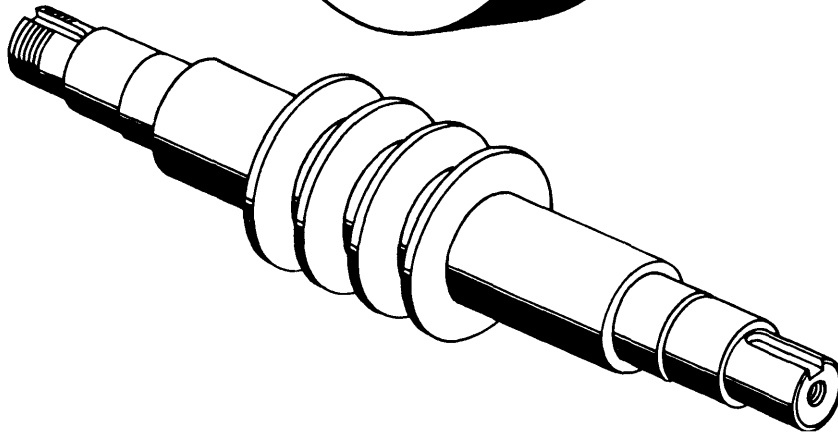

Authorized Distributor:
Pacific Marine & Industrial
www.pacificmarine.net
info@pacificmarine.net

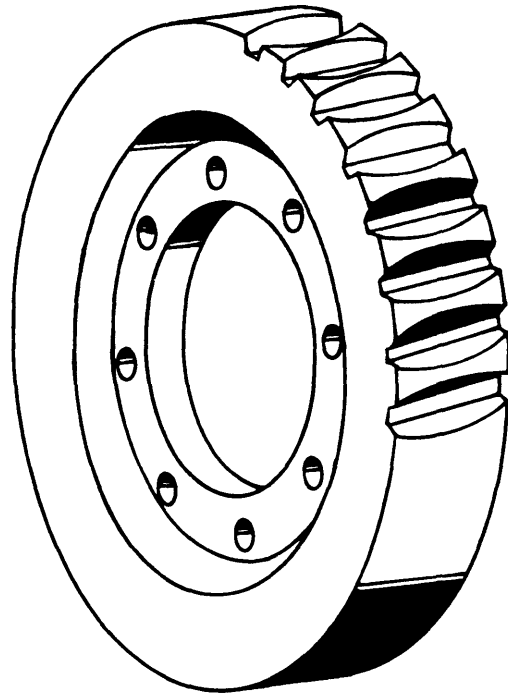

Tulsa Winch

Pacific Marine & Industrial - www.pacificmarine.net

24-SLLRO

| Item | Description | Qty. | Part No. | Item | Description | Qty. | Part No. | Item | Description | Qty. | Part No. |
|------|--------------|------|----------|------|--------------------|------|----------|------|----------------|------|----------|
| 1 | Rod | 1 | 20434 | 30 | Spring | 1 | 20299 | 55 | Bearing | 2 | 20303 |
| 2 | Bracket | 1 | 20426 | 31 | Drag Brake Ass'y | 1 | SA1413 | 56 | Housing | 1 | 21530 |
| 3 | Cotter Pin | 1 | 20819 | 32 | Clutch | 1 | 20424 | 57 | Name Plate | 1 | 21184 |
| 4 | Set Screw | 1 | 20515 | 33 | Frame L.H. | 1 | 20432 | 58 | Drive Screw | 4 | 21775 |
| 5 | Washer | 1 | 20096 | 34 | Capscrew | 8 | 939262 | 59 | Nut | 4 | 20271 |
| 6 | Cotter Pin | 1 | 20821 | 35 | Capscrew | 1 | 20823 | 60 | Lock Washer | 5 | 20526 |
| 7 | Yoke | 1 | 20428 | 36 | Roller | 1 | 30563 | 61 | Pipe Plug | 2 | 20286 |
| 8 | Key | 2 | 20431 | 37 | Washer | 2 | 23591 | 62 | Dowel Pin | 2 | 20517 |
| 9 | Washer | 1 | 20430 | 38 | Bracket Ass'y | 2 | SA3343 | 63 | Lock Washer | 10 | 20519 |
| 10 | Drum | 1 | 20422 | 39 | Capscrew | 4 | 28578 | 64 | Nut | 10 | 20273 |
| 11 | "U" Bolt | 1 | *31514 | 40 | Capscrew | 2 | 170177 | 65 | Worm, L.H. | 1 | 21640 |
| 12 | Bushing | 2 | 32839 | 41 | Washer | 2 | 20617 | | Worm, R.H. | 1 | 21641 |
| 13 | Shaft | 1 | 22439 | 42 | Cam | 1 | 23875 | 66 | Cap | 1 | 21542 |
| 14 | Key | 2 | 20574 | 43 | †Drive Screw | 3 | | 67 | Washer | 1 | 20092 |
| 15 | Nut | 1 | 23017 | 44 | †Instruction Plate | 1 | | 68 | Capscrew | 1 | 20278 |
| 16 | Gear Carrier | 2 | 22438 | 45 | Cam Plate | 1 | SA3568 | 69 | Key | 1 | 25393 |
| 17 | Bushing | 2 | 32840 | 46 | Brake Shoe Ass'y | 2 | SA1733 | 70 | Frame, R.H. | 1 | 20433 |
| 18 | Spacer | 1 | 20569 | 47 | Nut | 1 | 20114 | 71 | Gear, L.H. | 1 | 21642 |
| 19 | Dowel Pin | 2 | 164056 | 48 | Lock Washer | 1 | 20115 | | Gear, R.H. | 1 | 21643 |
| 20 | Capscrew | 2 | 27390 | 49 | Key | 1 | 20279 | 72 | Gasket | 2 | 20326 |
| 21 | Lock Washer | 2 | 20558 | 50 | Drum | 1 | 29503 | 73 | Cover | 1 | 40468 |
| 22 | Lock Washer | 8 | 20520 | 51 | Grease Retainer | 2 | 20281 | 74 | Capscrew | 4 | 33469 |
| 23 | Nut | 8 | 20274 | 52 | Capscrew | 16 | 30205 | 75 | Capscrew | 4 | 20268 |
| 24 | Poppet | 1 | 939264 | 53 | Housing | 1 | 21365 | 76 | Grease Fitting | 5 | 21128 |
| 25 | Spring | 1 | 20444 | 54 | Gasket | 2 | 20118 | 77 | Breather | 1 | 26799 |
| 26 | Bushing | 1 | 32842 | | | | | 78 | Capscrew | 10 | 21157 |
| 27 | Bracket | 1 | 20765 | | | | | 79 | Roll Pin | | |
| 28 | Lock Washer | 1 | 20518 | | | | | 80 | Lock Washer | 4 | 20518 |
| 29 | Nut | 1 | 20267 | | | | | 81 | Nut | 4 | 20267 |

†Part of SA3568 Cam Plate

*"J" Bolt Used on Model 24.

BRAKE ADJUSTMENT

FREQUENCY: Brake adjustment should be checked daily during heavy use or after one (1) hour of winch operation. Inspection of brake shoes and drum for wear should be made after every ten (10) hours of winch operation.

PROCEDURE:

To Adjust Brakes:

1. Remove load from winch cable.
2. Remove sprocket, coupler, universal joint, or motor from input shaft of winch.

Note: If power source to winch requires no appreciable torque to turn in a "Neutral" or "Off" position and an adapter can be made to fit the coupling, this step is not necessary.

3. Using a suitable adapter, place a torque wrench on the input shaft of the winch (65).
4. Measure torque while turning the input shaft in the *payout* direction. Torque settings should be as follows:

| Model | Torque (lb.-ft.) |
|-------|------------------|
| 24 | 70 |

Note: The torque value above is necessary to brake the rated load of the winch. In no case should the brake setting ever be increased above this torque value.

5. To adjust the brake torque, loosen the two cap screws (40) and rotate the cam (42). To increase the brake setting, rotate away from the "0" or center setting. To reduce the brake setting, rotate the cam back toward the "0" or center setting.
6. Recheck the torque value as indicated in 4. above.

To Inspect or Repair Brakes:

1. Loosen and remove cap screws (40) and washers (41) from brake assembly.

2. Gently pry the cam (42) out of the cover (45).

Caution: Be sure to note which set of drilled and tapped holes were used to position the cam. Failure to re-install the cam in this position will result in the brake engaging in the inhaul rather than the payout mode.

3. Remove the cap screws (39) from the cover (45).
4. Remove the cover (45) from the brake housing (53).
5. The brake shoes (46) may now be removed for inspection.
6. If the shoe linings are worn flush with the rivet heads, they should be replaced.
7. Inspect the drum (50) for severe wear or scoring. If necessary, replace the drum.
8. To remove the brake drum, remove the nut (47) and washer (48).
9. Insert two cap screws in the holes provided in the brake drum and, using a gear puller, remove the drum.
10. Inspect the inside lower part of the brake housing for the presence of oil. If an oil leak exists, replace the seal (51).

To Change Direction of Brake Engagement:

1. Remove cap screws (40) and washers (41).
2. Rotate cam (42) in either direction until another set of drilled and tapped holes becomes visible through the slots in the cam.
3. Re-install the cap screws (40) and washers (41) in these tapped holes.
4. Adjust brake as described above.

Caution: Any change in winch mounting, direction of cable spooling, or replacement of worm and gear may effect the operation of the brake. If you have any question about the performance of the brake on your Tulsa winch, stop using it immediately and contact Tulsa Winch, or one of our authorized distributors.

Model Code:

| * | 24 | — | S | L | L | R | O |
|--|-------------------------|---|---|-------------------------------------|---|--|--|
| TYPE UNIT (Omit if Basic Unit) G = Speed Reducer | SERIES 24 = Model 24 | | TYPE WORM D = Double Lead S = Single Lead | WORM ANGLE L = Left R = Right | GEAR BOX LOCATION (From Behind Truck) L = Left R = Right | INPUT SHAFT LOCATION (Relating to Truck) F = Front R = Rear | CABLE SPOOL O = Over Drum U = Under Drum |

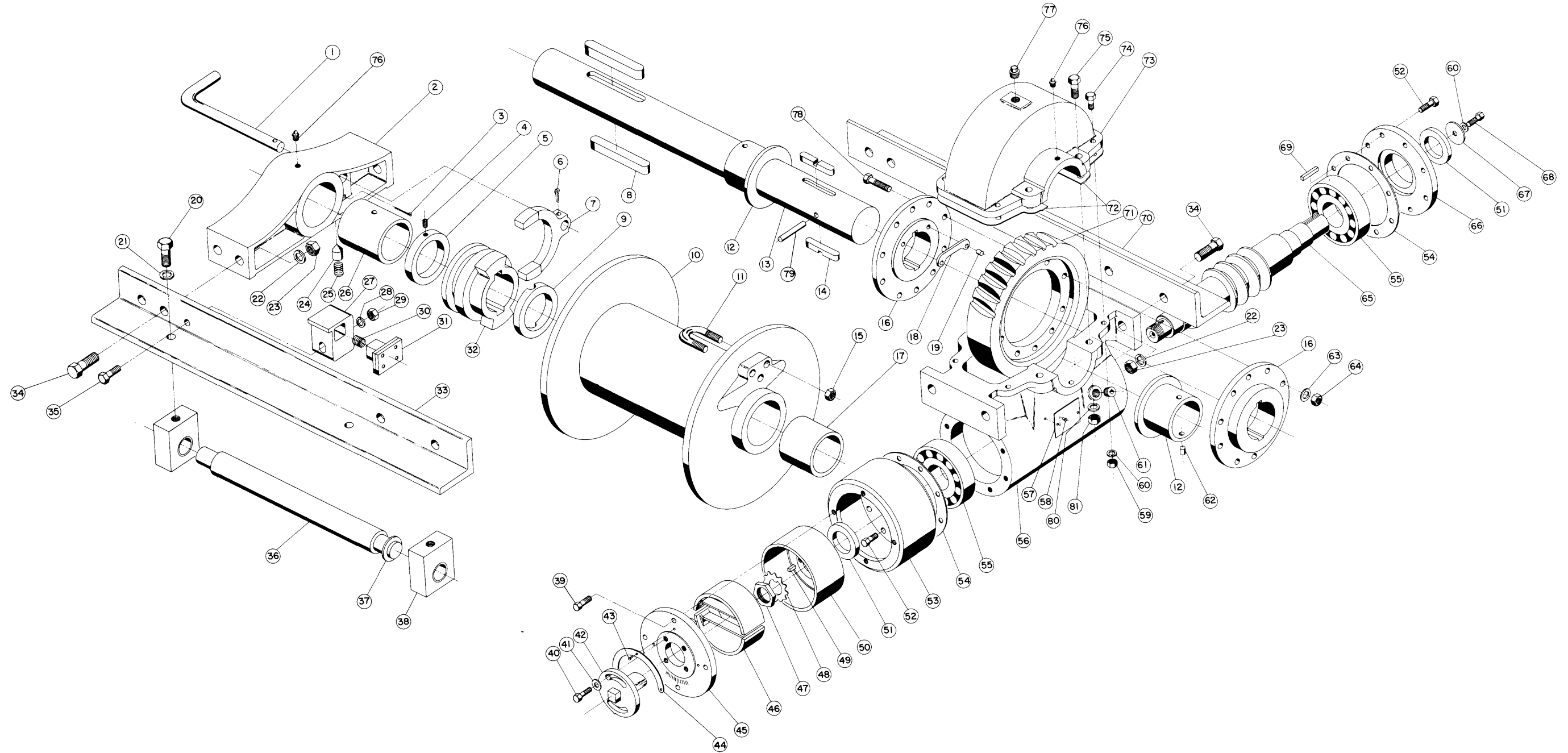

Warning: Not Approved for Personnel Lifts!
Read Operating and Safety Manual Before Using Any Winch!

Authorized Distributor:
Pacific Marine & Industrial
www.pacificmarine.net
info@pacificmarine.net

General Information

Operating Characteristics

TULSA winches are worm-gear driven designed for heavy loads at slow speeds and for intermittent duty. Drum capacities for cable are not excessively large, purposely to protect the worm and gear in the winch from prolonged pulls under heavy loads which might generate enough heat to permanently damage the worm, gear and bearings. Due to the fact that most loads are seldom steady, but are usually jerking or vibrating, imposing a load on the winch several times the actual weight being lifted, the lubricant used in the worm gear case must be of the highest quality and it is necessary to have a safety brake. The worm and gear in Tulsa winches (except for the special high speed winches using double thread worm and gear) are of the low helix angle, low efficiency type. The low efficiency of the worm and gear means that a good part of the energy transmitted in the winch is converted into heat which must be dissipated through the lubricant to the outside air.

Tulsa Winches are equipped with a reverse draft clutch, which cannot be disengaged while the winch is under load. This feature, along with the automatic worm safety brake, insure that a load must be lowered under power. When the winch is not under load, the drum clutch can be disengaged, permitting the operator to spool line off the drum by hand, thus saving wear on the automatic safety brake, as well as other parts of the winch.

All Tulsa winches are equipped with either a drum band brake or a drum drag brake which facilitates spooling line off the drum by preventing over-running and tangling. These brakes are applied by a manual control lever or automatically.

Automatic Worm Brake Assembly

THE AUTOMATIC WORM BRAKE of Tulsa winches can be assembled with right hand or left hand cam settings. The automatic worm brake is designed to completely release in the forward speed of the worm or the load lifting direction of the worm, and automatically brake in the reverse direction of the worm or when a load on the winch tends to rotate the worm in reverse. When a load is held suspended by the automatic brake, a small amount of reversing power is necessary to lower the load and therefore, **the worm brake should be tightened only to that amount necessary to suspend the maximum load to be handled.** This will reduce wear to a minimum on the brake linings and prevent unnecessary heating in reverse or the load-lowering operation. The direction of

tightening the worm brake is shown on the outside of the cam and the "hand" of the cam should be such that the tightening direction is in the forward rotation of the worm, or the load-lifting rotation of the worm, for the automatic brake to operate satisfactorily.

The automatic worm brake operates dry and is cam operated. The cam of the cam-type brake can be set in either of two positions, depending upon the direction of rotation of the worm shaft in the load raising direction and the hand of the worm and gear installed in the winch. The cam must be installed in the correct position or the brake will not function.

WHEN SPOOLING LOOSE CABLE OFF THE DRUM, disengage the clutch and pull cable off manually. This eliminates unnecessary wear on the worm brake linings.

The worm brake is easily adjusted by loosening or removing cap screws as necessary and turning the cam in the direction of the tightening arrow. All brake linings wear and it is necessary to adjust the worm brake from time to time depending on the frequency of its use. It will become apparent when the lining is worn — the brake will begin to slip and will not hold a load. At this point the brake should be adjusted, or, if already tight as possible, the brake shoes should be relined and other worn parts replaced.

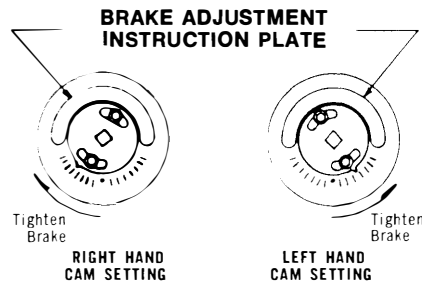

A DRUM BRAKE ASSEMBLY is furnished on our winches to retard the speed of the cable drum when spooling off loose cable. Use of the brake in "free-spooling" of the cable drum prevents tangling of the cable on the drum.

Suggestions and Precautions

1. **"Wear-in Period"** — Winches, like other machinery, should be operated carefully during the first few hours of operation. Frequent cooling-off periods are essential to prevent over-heating.
2. **Cable Sizes** — Never use larger size cable than is shown on current catalog literature for the winch model being used.
3. **Slow Speeds—Intermittent Duty** — Op-

eration at slow speeds with intermittent operation are essential to prolong the service of worm-gear winches.

4. **Shock Loads** — Avoid shock loads. This type of load imposes a strain on the winch many times the actual weight of the load.
5. **Engaging Winch Clutch** — Always make certain that winch clutch is either completely engaged or disengaged (as desired) to save wear on clutch jaws and insure safety.
6. **Operating Cycle** — The operating cycle consists of:
 - (a) Disengaging winch drum clutch and pulling off enough cable to allow hooking to load. The drum brake should be used to keep drum from rolling too fast and thereby entangling cable.
 - (b) After hooking to load engage drum clutch and release the drum brake.
 - (c) Depress engine clutch pedal and shift power take-off into forward speed using low speed for heavy loads.
 - (d) Release engine clutch pedal and winch will reel in cable.
 - (e) The winch is stopped by depressing engine clutch pedal and the load will be held by the automatic brake on the end of the worm shaft.
 - (f) To lower the load or to remove cable from load, shift power take-off into reverse and release engine clutch pedal. The winch will then unreel cable.

Always keep in mind the **load to be handled should not exceed safe working load of the winch.** Safe working loads are figured on the first layer; therefore, for each layer of cable on the drum, the load the winch will handle is reduced.

Oil Capacity

| Winch Model | Capacity | SAE Viscosity | Application |
|-------------|----------|---------------|-----------------------------------|
| 24 | 3 Qts. | 140 | Factory Installed for Normal Duty |



Authorized Distributor:
Pacific Marine & Industrial
www.pacificmarine.net
info@pacificmarine.net



TWG
PO Box 1130
Jenks OK 74037-1130
USA Phone:
918-298-8300
www.dovertwg.com



Authorized Distributor:
Pacific Marine & Industrial
www.pacificmarine.net
info@pacificmarine.net

Litho in U.S.A. PL24-92