

BRADEN



Authorized Distributor:
Pacific Marine & Industrial
www.pacificmarine.net
info@pacificmarine.net

MODEL HP50B-LP

UP TO 50,000-POUND LINEPULL

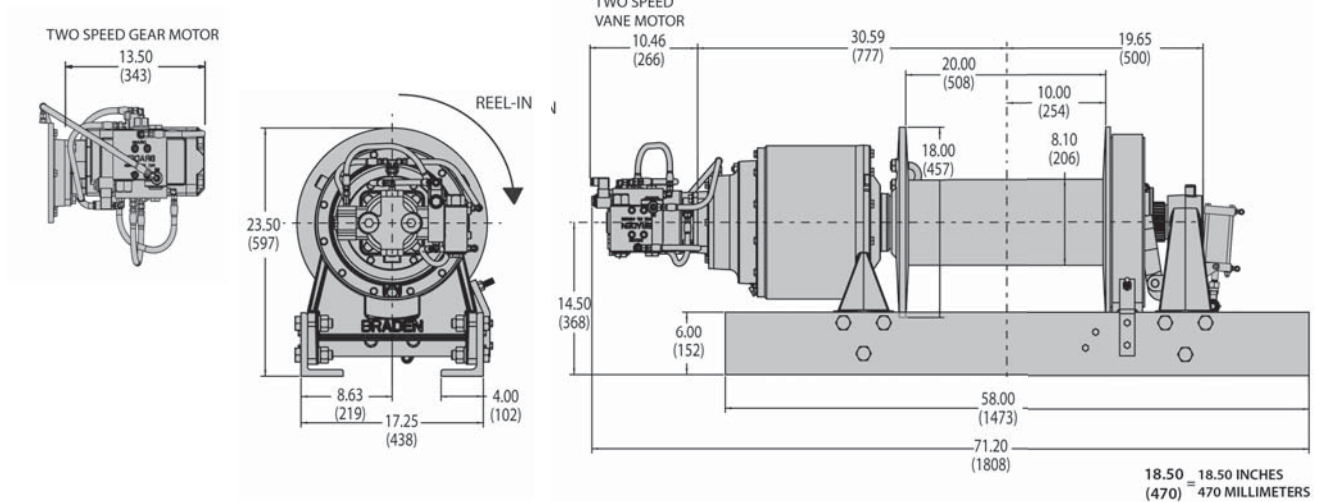

- 50,000 lbs. First Layer
- Planetary Gearing for High Efficiency
- Gear or Vane Motor Available

- Multi-disc Wet Brake for Firm Hold
- Air Actuated Sliding Drum Clutch
- Patented Brake Valve for Smooth/Reliable Load Control

Specifications

HP50B-LP-104077/038-01

7.66/3.83 cu in. 2-Speed Gear Motor (125/63cc)
2240 PSI (154 bar) @ 60 gpm (227 lpm)
Wire Rope Diameter: 7/8"

	LOW SPEED				HIGH SPEED				ROPE CAPACITY	
	LINE PULL		LINE SPEED		LINE PULL		LINE SPEED			
	LB	KG	FPM	MPM	LB	KG	FPM	MPM	FT	M
1	50,000	22,730	31	9	23,700	10,770	62	19	37	11
2	40,900	18,600	37	11	19,400	8,800	75	23	83	25
3	34,600	15,700	44	13	16,400	7,450	89	27	137	42
4	30,000	13,600	51	16	14,200	6,450	103	31	199	62
5	26,500	12,000	58	18	12,550	5,700	117	36	270	82
6	23,700	10,800	65	20	11,200	5,100	131	40	349	106

* Rope capacity based on 90% of theoretical

HP50B-LP-104080/040-01

8.00/4.00 cu in. 2-Speed Vane Motor (130/65cc)
2000 PSI (152 bar) @ 50 gpm (190 lpm)
Wire Rope Diameter: 7/8"

	LOW SPEED				HIGH SPEED				ROPE CAPACITY	
	LINE PULL		LINE SPEED		LINE PULL		LINE SPEED			
	LB	KG	FPM	MPM	LB	KG	FPM	MPM	FT	M
1	50,000	22,730	26	8	24,200	11,000	53	16	37	11
2	40,900	18,600	32	10	19,800	9,000	65	20	83	25
3	34,600	15,700	38	12	16,750	7,600	77	23	137	42
4	30,000	13,600	44	13	14,500	6,600	89	27	199	62
5	26,500	12,000	50	15	12,800	5,800	101	31	270	82

* Rope capacity based on 90% of theoretical

Wire Rope Storage Capacities

-01 DRUM CAPACITY [inches] (7.00" B x 18.00" F x 17.75" W)							
	1	2	3	4	5	6	7
3/4"	43	94	150	220	300	380	480
7/8"	37	83	137	199	270	350	

-01 DRUM CAPACITY [meters] (7.00" B x 18.00" F x 17.75" W)							
	1	2	3	4	5	6	7
3/4"	13	28	46	67	91	115	146
7/8"	11	25	42	62	82	106	

LIT2297 R3 9-2009