

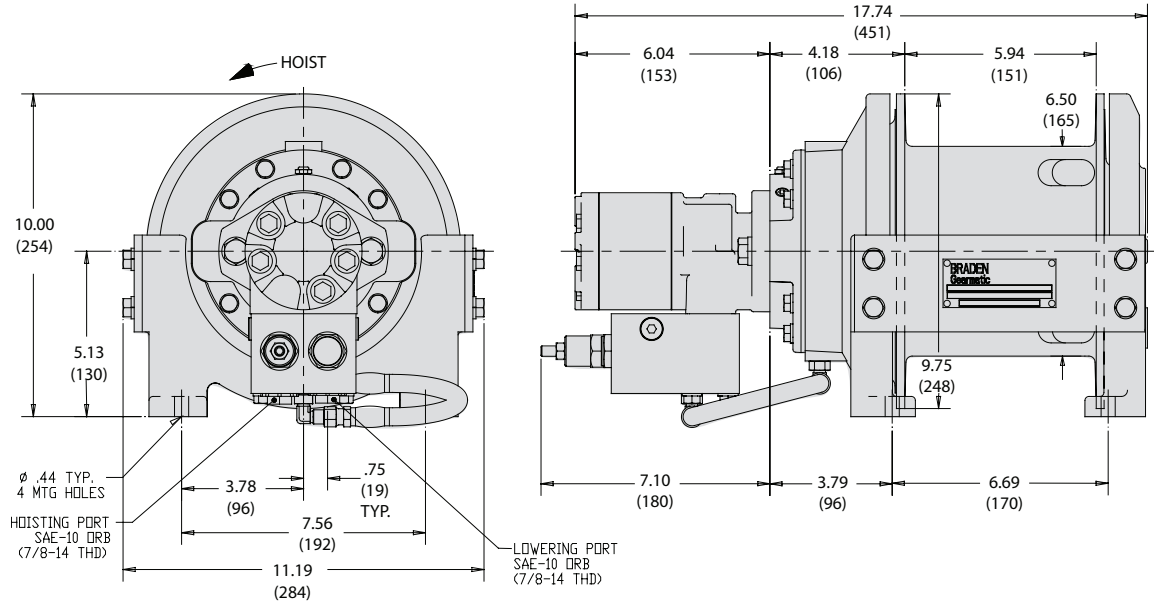

Authorized Distributor:
Pacific Marine & Industrial
 www.pacificmarine.net
 info@pacificmarine.net

BRADEN

MODEL BG3B UP TO 3,800-POUND LINEPULL



- 3,800 lbs. First Layer
- Multi-disc Spring
- High Efficiency Motor

BG3B-05080-01

8.0 cu in. Motor (131cc)
 2488PSI (171 bar) @ 15 gpm (57 lpm)
 Wire Rope Diameter: 3/8"

	LINE PULL		LINE SPEED	
	LB	KG	FPM	MPM
1	3,000	1,364	140	43
2	2,700	1,227	155	47
3	2,460	1,118	170	52
4*	2,260	1,027	186	57

* Layer does not meet ANSI B30.7

BG3B-05119-01H

11.9 cu in. Motor (195cc)
 2119PSI (146 bar) @ 15 gpm (57 lpm)
 Wire Rope Diameter: 3/8"

	LINE PULL		LINE SPEED	
	LB	KG	FPM	MPM
1	3,800	1,727	94	29
2	3,430	1,559	104	32
3	3,120	1,418	114	35
4*	2,860	1,300	125	38

* Layer does not meet ANSI B30.7

Wire Rope Storage Capacity

BG3B & BG3B-01H DRUM CAPACITY (6.5" B x 9.75" F x 5.88" W)							
	D/d	1	2	3	4	5	6
1/4 in.	27:1	41	85	132	182	235*	291
6 mm		x	x	x	x	x	x
3/8 in.	18:1	28	59	93	130*		
10 mm		x	x	x	x		

* Layer does not meet ANSI B30.7