

1021154

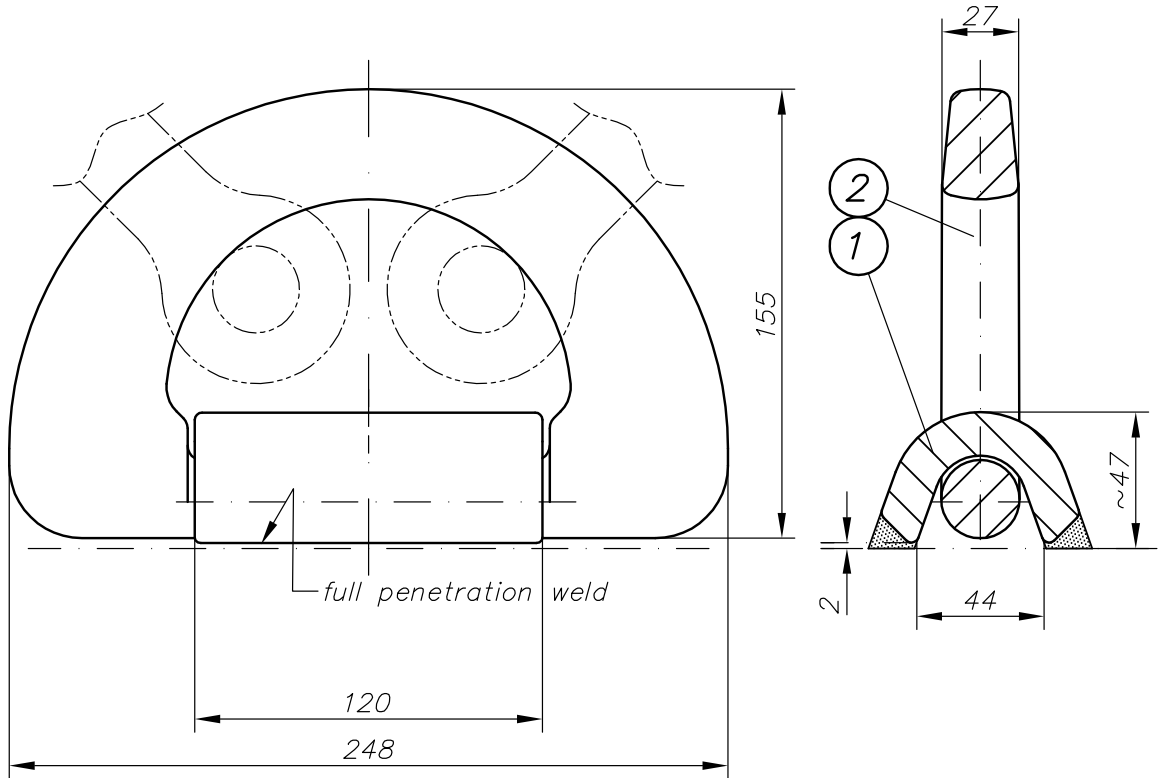

**Welding:**

Preferable low hydrogen-electrodes (lime basic electrodes); e.g. AWS/ASME SFA-5.1 E7016 or E7028.

2	EPL-ZA3	1006569
1	AS-3	1006581
POS	Description	SAP-No.
Spare part list		

Class approval: acc. to order confirmation  
 Nom. breaking load: Tension: 490 kN (50t)

Material: Pos 1: S355J2G3 or equivalent  
 Pos 2: high tensile steel  
 Finish: acc. to order confirmation

File No.: 5,6 kg  
 Index:  
 Drawn by: RWK  
 Date: 22.03.02  
 Dwg. No.: R0910.1122  
 File No.: R09101122

Copying of this document and giving it to others and the use or communication of contents thereof, are forbidden without express authority. Offenders are liable to the payment of damage. All rights are reserved in the event of the grant of patent or registration of the utility model or design. Modifications of design are reserved.