

1003842

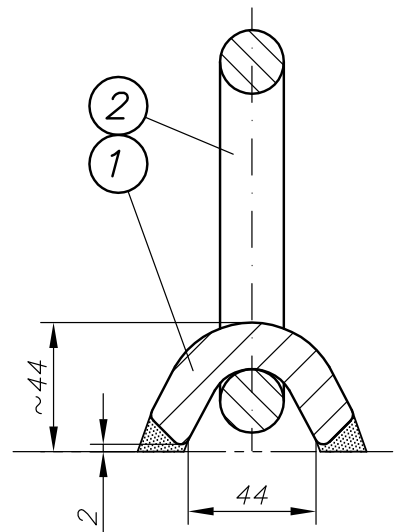
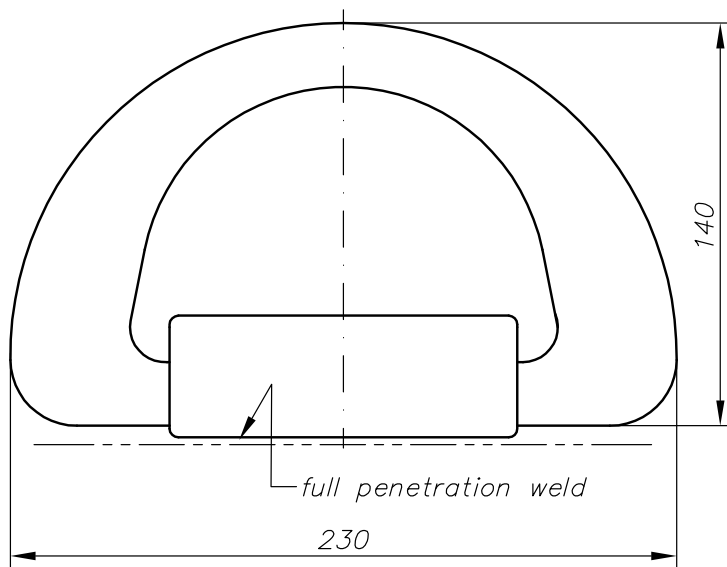

**Welding:**

Preferable low hydrogen-electrodes (lime basic electrodes); e.g. AWS/ASME SFA-5.1 E7016 or E7028.

Class approval: acc. to order confirmation  
 Nom. breaking load: Tension: 360 kN

Material: Pos 1: S355J2G3 or equivalent  
 Pos 2: high tensile steel  
 Finish: acc. to order confirmation

Weight: 3,9 kg  
 Index:  
 Drawn by: RWK  
 Date: 22.03.02  
 Dwg. No.: R0910.1111  
 File No.: R09101111  
 Project No.:

Copying of this document and giving it to others and the use or communication of contents thereof, are forbidden without express authority. Offenders are liable to the payment of damage. All rights are reserved in the event of the grant of patent or registration of the utility model or design. Modifications of design are reserved.