

# SELECTRONIC® Micro-Controller/Annunciator

## Series 1501



- Alarm/Shutdown for 32 or 64 N.O. or N.C. Sensors
- Operating Sequence Selection
- Field Adjustable Sensor Nomenclature
- Selectable Sensor Lockouts Class A, B, C or P
- Built-In Tachometer/Overspeed Function
- RS232 or RS485 Modbus RTU Communications
- Two Start/Run Timers and Elapsed Time Meter
- CSA Certified or NRTL Approved for Use in Class I, Div. 1 Grps. C & D Hazardous Locations

### Description

The Series 1501 is a microprocessor-based alarm, shutdown and control system with tachometer/hourmeter function. It annunciates in alphanumeric characters the protective device that has signaled an alarm or caused equipment shutdown. Information is called up and adjustments are made on a six-button keypad on the face of the unit. Configurations such as: Alarm or Shutdown Nomenclature, Preset Timers, and Tachometer Calibration can be made in the field.

Murphy's Series 1501 has seven SPDT relays. On the standard model, the relays are assigned to the following functions: Lube, Crank, Ignition/Motor, Fuel Valve, Load, Alarm, Shutdown.

The complete Series 1501 system consists of a head (monitor), sensor input terminal strip (two needed for 64 sensor models), 36 inch (914 mm) flat ribbon cable(s) for connecting the terminal block to the head/monitor, and a Class I, Div. 1, explosion-proof power supply.

The Series 1501 is powered from 120 VAC or 12 or 24 VDC. The head/monitor is rated intrinsically safe and includes a communication port: RS232 or RS485 (Modbus RTU slave). This port allows for remote control functions such as Start/Stop, Load/Unload, etc., and for access to Series 1501 registers.

### Applications

The Series 1501 can be configured to monitor applications such as: Air and Gas Compressors, Natural Gas Refueling, and other Industrial Operations. For a list of applications and our cataloged programs contact a Murphy sales representative. Custom programming available at additional charge.

### Features

- 32 or 64 sensor inputs (N.O. or N.C.) for alarm or shutdown.
- Easy operation/adjustments Six-button keypad.
- RS232 or RS485 Modbus RTU communications.
- Automatic Engine Control.
- Two Start-Run Timers.
- Seven Control Relay Outputs.
- Pre/Postlube Time Delay.
- Automatic Compressor Loading.

### Specifications

**Power Consumption:** 120 VAC (7.5 VA); 12 VDC (3.5 watts); 24 VDC (3.5 watts).

**Sensor Inputs:** 32 to 64 N.O. and/or N.C. inputs such as Murphy SWICHGAGE® instruments. Field selectable as a Class A, B1, B2, C, P or ESD for shutdown, alarm, or control function.

**Outputs:** 7-SPDT relay outputs, 5 A, 1/16 HP, 125/250 VAC/ 1 A, 30 VDC.

**NOTE:** For hazardous areas an approved isolation barrier must be used between sensor switch and input terminals if the sensor output comes from any energy storing device such as a relay or transistor.

### Adjustable Time Delays: (standard Series 1501)

- Prelube
- Rest
- Process Delay
- Permissive
- Run Delay
- Idle/Cooldown
- Purge
- Postlube
- Fuel Delay
- Crank
- Load Delay
- Test
- Class B1 Sensor Lockout
- Class B2 Sensor Lockout
- Before Ignition Ground or Electric Motor Stop (for up to 59 seconds)

**Sensor Inputs Terminal Block:** Rail mount DIN type; 32 terminals, screw type.

**Opto-Isolated Tach/Run Input:** Magnetic pick-up, 4.5 to 120 Vrms, 0-10 kHz. CD ignition, positive or negative ground, 100 to 300 VDC, 3-666 Hz. 12 to 125 VDC or 120 Vrms, 50/60 Hz may be used for run signals.

**Operating Temperatures:** 32 to 122°F (0 to 50°C).

**Storage Temperatures:** -4 to 158°F (-20 to 70°C).

**Case:** ABS plastic, 1/4 DIN (90 x 90 mm).

**Interface Output:** Factory configured for RS232; field-selectable for RS485 (specify for factory configured RS485).

**Alphanumeric Display:** 2 lines, each line with 16 characters (32 characters total).

**Power Supply Enclosure:** *Explosion-proof, Class I, Division 1. Intrinsically safe barrier built into the power supply, 120 VAC with 7 form "C" relay outputs for the following functions (with standard S1501):*

- Lube
- Load
- Crank
- Alarm
- Ignition/Motor
- Shutdown
- Fuel Valve

## How to Order

To order the Series 1501 specify the model number for each individual component and accessory:

<i>Specify:</i>	<i>To Order:</i>
<b>S1501H-32-2</b>	Head with RS232 port for 32 sensors.
<b>S1501H-64-2</b>	Head with RS232 port for 64 sensors.
<b>S1501H-32-4</b>	Head with RS485 port for 32 sensors.
<b>S1501H-64-4</b>	Head with RS485 port for 64 sensors.
<b>S1501CH-32-2</b>	Head w/custom* program, RS232 port, 32 sensors.
<b>S1501CH-64-2</b>	Head w/custom* program, RS232 port, 64 sensors.
<b>S1501CH-32-4</b>	Head w/custom* program, RS485 port, 32 sensors.
<b>S1501CH-64-4</b>	Head w/custom* program, RS485 port, 64 sensors.
<b>S1501CC48</b>	Communications Cable Assembly, 48 in. (1.2 m) long.
<b>S1500TB32</b>	Terminal Block only**
<b>S1500CA36</b>	Ribbon Cable Assembly**
<b>S1501PS-120</b>	120 VAC, 12 or 24 VDC Power Supply.

### Accessories:

<b>S1501PCA72</b>	Power and Control Cable Assembly, 72 in. (1.8 m) long.
<b>S1501PS-120-E</b>	Power Supply with 90° Conduit Elbow fitting.
<b>S1501PS-120-LC</b>	Power Supply Less Case.

\* Specify program number or contact Murphy for available programs listings.

\*\* Two required for 64 sensor models.

## Approximate Shipping Weights

Complete Series 1501 System: 28 lb. (12.7 kg).

**S1501H-32-2; S1501H-64-2; S1501H-32-4; S1501H-64-4; S1501CH-32-2;**

**S1501CH-64-2; S1501CH-32-4; S1501CH-64-4:** 2 lb. (0.907 kg).

**S1500TB32:** 2 lb. (0.907 kg).

**S1500CA36; S1501CC48; S1501PCA72:** 2 lb. (0.907 kg).

**S1501PS-120-LC:** 3 lb. (1.36 kg).

**S1501PS-120 and S1501PS-120-E:** 22 lb. (9.98 kg).

## Approximate Shipping Dimensions

Complete Series 1501 System: 20 x 14 x 12-1/2 in. (508 x 356 x 318 mm).

**S1501H-32-2; S1501H-64-2; S1501H-32-4; S1501H-64-4; S1501CH-32-2;**

**S1501CH-64-2; S1501CH-32-4; S1501CH-64-4:** 6 x 6 x 6 in. (152 x 152 x 152 mm).

**S1500TB32:** 12 x 7 x 4 in. (305 x 178 x 102 mm).

**S1500CA36; S1501CC48; S1501PCA72:** 6 x 6 x 6 in. (152 x 152 x 152 mm).

**S1501PS-120-LC:** 12 x 7 x 4 in. (305 x 178 x 102 mm).

**S1501PS-120 and S1501PS-120-E:** 17 x 10 x 9-3/4 in. (431 x 254 x 248 mm).

## Warranty

A two-year limited warranty on materials and workmanship is given with this Murphy product. Details are available on request and are packed with each unit.

## Dimensions

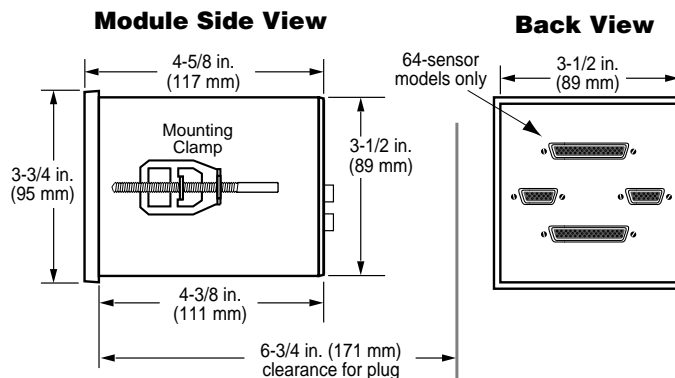

## Terminal Block

