

# Digital Fault Annunciator TATTLETALE®

by Murphy ELECTRONIC®

MK4-93001B  
Revised 11-02  
Catalog Section 50  
(00-02-0117)

FWMurphy



## MARK IV Series

- Monitors Engine Driven Pumps and Compressors for Alarm and Shutdown
- Built-in Power Supply
- 47 Sensors Can Be Displayed
- Monitors Low Ignition Voltage or Failure
- CSA\* and FM Listed for Class I, Division 2, CSA for Groups C and D Hazardous Areas  
FM for Group D Hazardous Areas

### Description

The MARK IV series control system is an electronic fault annunciator and alarm/shutdown TATTLETALE® designed to protect engines and associated equipment. The power supply is built into the display head and receives its input from negative ground CD ignitions or by 12 or 24 VDC battery. The MARK IV receives its fault signal inputs from normally open sensors such as standard Murphy SWICHGAGE® instruments. Fault in any of its 47 input sensors will annunciate via an LCD digital display.

A 5-minute start-run timer is displayed during start-up. The unit also features a test mode which allows testing of the sensor circuits without shutting down the equipment.

A backup battery is included to retain the fault display after engine shutdown. The MARK IV provides for both closing of a fuel valve and grounding of the ignition for shutdown. If desired, a 3-second time delay will allow a delay in grounding the ignition after the fuel valve closes.

The MARK IV-N (ignition powered model) includes an internal low ignition voltage or ignition failure monitoring function. When the ignition voltage drops below control system minimum power requirements, the number 15 is displayed indicating the malfunction.

**CAUTION:** We do NOT recommend the use of switches having contacts immersed in oil. Because the MARK IV operates on low voltage, the oil may act as an insulator between the contacts.

### Features

- You save with the BUILT-IN POWER SUPPLY.
- Plug-in sensor terminal blocks.
- Up to 47 sensors can be connected and displayed for alarm and shutdown.
  - Sensors 1–15 are used for timed, alarm-override at start-up.
  - Sensor 15 also connected to internal ignition voltage monitor.
  - Sensor 46 is dedicated for electronic digital speed switches with SCR output.
  - Sensor 47 is dedicated for manual stop.
- 4-Point compression screw type connection block for convenient hook up to power and control outputs.
- An easy-to-read liquid crystal display that indicates the tripped sensor and allows you to view the timer countdown during the start-up period.
- Use the test timer to override shutdown during sensor tests (indicates tripped sensor without shutdown).
- 3-second time delay allows the fuel valve to close before grounding the ignition.
- Low battery voltage alert displayed on the left side of timer window.

### Specifications

**Power:** Negative ground CD ignition: 90 to 250 VDC; 12 or 24 VDC.

**NOTE:** MARK IV CANNOT be powered by a magneto ignition.

### Power Inputs (Operating Voltages):

MARK IV-N: 90-250 VDC, CD ignition (negative ground only).

MARK IV-12/24: 12-24 VDC 0.7 VA maximum (4.7 watts with 2 customer-supplied, typical hermetically sealed relays).

**Power Consumption:** 450  $\mu$ A, 100 VDC.

**Sensor Inputs:** Sensor switches with grounding contacts such as Murphy SWICHGAGE® instruments.

**NOTE:** An isolation barrier must be used between sensor switch and input terminals if sensor outputs come from any energy storing device such as relay or transistor.

**Outputs:** MARK IV-N and MARK IV-12/24: FET (Field Effect Transistor) rated @ 0.5 A, 250 V maximum.

**Operating Temperature:** -4 to 158°F (-20 to 70°C).

**Storage Temperature:** -40 to 302°F (-40 to 150°C).

**Case:** Anodized aluminum.

**Multiplexer Scan Rate:** Scans all 47 sensors in 0.5 seconds.

**Start-Run/Test Time:** Standard 5 minutes, specify other, up to 7 minutes maximum.

**Laboratory Approvals:** CSA\* and FM listed for Class I, Division 2 hazardous areas. CSA listed for Groups C and D; FM listed for Group D.

**Backup Power:** On-board 6 VDC @ 1300 mAh, DL223A lithium battery.

\*Rated 90–250 V, CD ignition or 12-24 VDC/4.7 W and non-incendive field wiring connections as per drawing

## MARK IV Dimensions

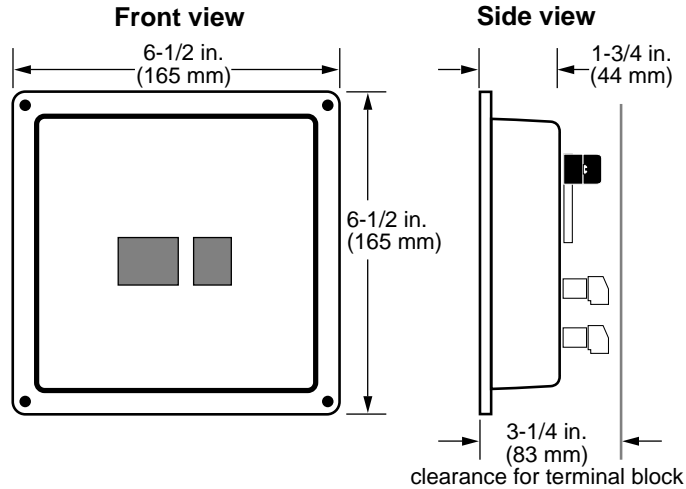

### Mounting Hole

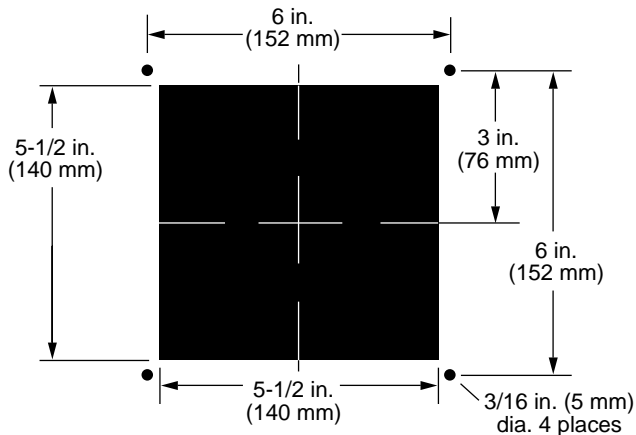

## How to Order

To order the MARK IV specify the letter "N" for CD negative ground ignition model, or "12/24" for 12-24 VDC model. These letters are to be indicated after the MARK IV. Example: **MARK IV-N**

**Shipping dimensions:** 7-1/2 x 9-1/2 x 3-1/4 in. (191 x 241 x 83 mm)

**Shipping Weight:** 1 lb. (.45 kg.).

## Warranty

A two year limited warranty on materials and workmanship is provided with this Murphy product. Details are available on request and are packed with each unit.

## Typical Wiring Diagrams

### MARK IV-N (back view)

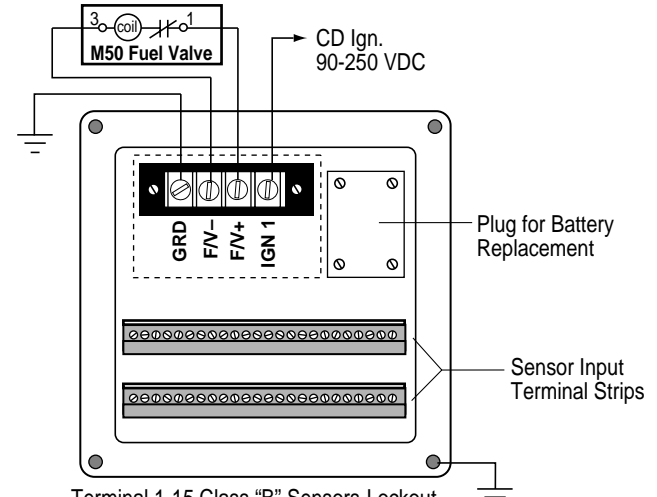

Terminal 1-15 Class "B" Sensors-Lockout.  
 Terminal 15 Also connected to internal Ignition Voltage Monitor.  
 Terminal 16-45 Class "A" Sensors-No lockout.  
 Terminal 46 dedicated for electronic digital speed switches with SCR output.  
 Terminal 47 is dedicated for manual stop.

### MARK IV-12/24 (back view)

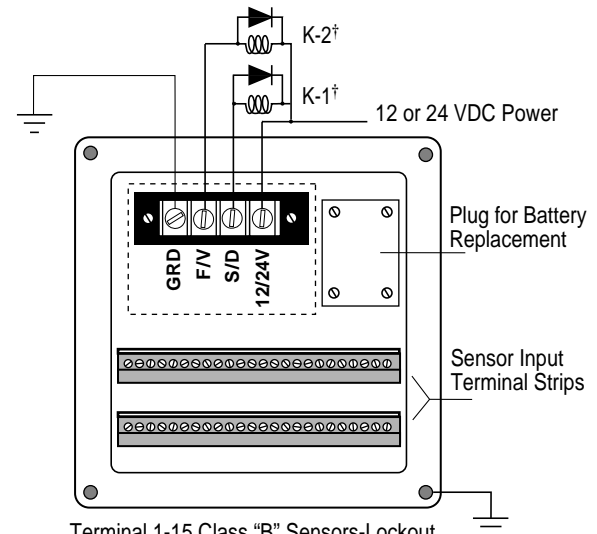

Terminal 1-15 Class "B" Sensors-Lockout  
 Terminal 16-45 Class "A" Sensors-No lockout  
 Terminal 46 dedicated for electronic digital speed switches with SCR output.  
 Terminal 47 is dedicated for manual stop.

† Relays energized to run; de-energized to stop.