

Electronic Monitoring System/Controller

EMS5-95122B
Revised 05-03
Catalog Section 40
(00-02-0102)

FWMurphy



Model EMS547

- Field Adjustable Parameters
- First-Out Shutdowns and/or Alarms
- Shutdown History File
- Service Reminders
- Four Communication Ports
- External PC Card Reader and Modem Ready
- Back Lit LCD or VFD Alphanumeric Display

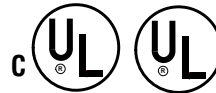

Approved for Class I, Division 2, Groups C & D areas.

Description

The EMS547 Electronic Monitoring System/Controller is micro-processor based for monitoring and control of equipment functions. It is especially suited to tasks requiring remote modem or SCADA communications. Four built-in communication ports provide a variety of communications capabilities. Basic programs provide selectable auto or manual start/stop and first-out shutdown for engine functions such as pressure, temperature, level and overspeed. Time delays for lockout during start up are included.

The EMS547 can be applied as an RTU to interface between SCADA applications and other control platforms. It can also be used, in conjunction with a Hayes compatible modem (9600 Baud), for remote communications.

An external PC Card reader can be used with the EMS547 to log data from flow meters, pressure transmitters, electric gage senders, and other sensing devices. This is a popular application in the flood control market.

Operating data is displayed on a 32 character back lit alphanumeric liquid crystal display. An on-board real-time clock keeps a log of equipment running hours and alerts you when to change oil, filters and perform other routine service.

The EMS547 operating parameters are configured through a simple three-button interface. Access to the system memory is controlled by entry codes.

A password-protected program uses built-in memory to display the alarm/shutdown history, including a display of the last ten shutdowns, when and why they occurred, and displays all of the engine operating conditions at time of last shutdown.

Because of the flexibility of this product, please call one of our application specialists to see how best to apply the EMS547. We have a growing library of standard programs or we can write a program to your specific needs.

Applications

- Industrial Engines
- Electric Motors
- Generators
- Construction Equipment
- Remote Cellular Sites
- Compressors
- Trucks
- Pumps
- SCADA

Specifications

Input Voltage: 10 to 28 VDC.

Operating Temperature: -4 to 149°F (-20 to 65°C).

Storage Temperature: -4 to 149°F (-20 to 65°C).

Relative Humidity: 95%RH @ 60°C (140°F).

Display: Alphanumeric: 2-line, 32 character backlit LCD (standard); VFD optional.

Communications: 2-RS485, 2-RS232 ports.

Sensor Inputs:

Digital: 4 optically-isolated inputs, (positive voltage or ground) such as from Murphy SWICH-GAGE® instruments.

Analog: Up to 8 inputs—will accept a variety of resistive sending units, such as from Murphy electric gage senders. (When resistive sending units are used, one input will be designated for battery voltage sensing.)

Optional: Special order analog inputs available, including end of line 4-20 mA and 0-5 VDC.

Frequency: 1 optically-isolated input for speed reference, such as MP3298 magnetic sensor.

Outputs:

Transistor: 7 digital; 125 mA sinking.

S449-1 Relay Board (Optional)*:

6 Dry Relay: 4 SPST, 5A @ 30 VDC, 250 VAC, 1/10 hp @ 120 VAC; 2 DPDT, 2A @ 220 VDC, 250 VAC ††.

S449-3 Relay Board (Optional)*:

2 Transistor digital: 125 mA sinking.
4 Relay: 2 SPST, 5A @ 30 VDC, 250 VAC, 1/10 hp @ 120 VAC; 2 DPDT, 2A @ 220 VDC, 250 VAC ††.

Shipping Weight: 2-1/4 lb. (1 kg.).

Shipping Dimensions: 9-1/4 x 8-1/4 x 5-1/4 in. (235 x 210 x 133 mm).

Warranty

A two-year warranty on materials and workmanship is given with this FWMurphy product. A copy of the warranty may be viewed or printed by going to www.fwmurphy.com/warranty.asp.

†† One DPDT pole has common connected to battery+. N.O. available fused and unfused.

**Not Class I, Division 2 approved.

Dimensions

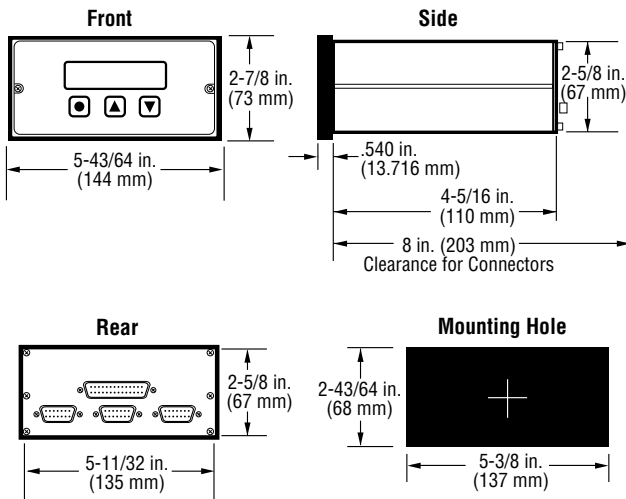

How to Order

Specify the model number using the following example:

EMS547 - V - V - A95113

Display

Blank = default LCD

V = vacuum fluorescent (VFD)

Case

Blank = non-vented

V = vented case

Specify Program Number

Program A95113 is the basic gen-set program.

Other basic or custom programs available.

*If known. Complete model number will be designed by Murphy when program and hardware specifics are known.

Accessories Required to complete the installation

Specify model number, example: EMS25RM

EMS25RM = Rail mount DIN type terminal block

† EMS25CAR2 = Ribbon cable with 2 male D-subminiature connectors

† EMS25TBCAR2 = Ribbon cable with 1 male and 1 female D-subminiature connectors

EMS25CAS = Male connector with 9 ft. (2.74 m) long color coded cable

EMS25MS = Solder type male D-subminiature connector

S449-1 = Relay board instead of S449-3 relay board.

S449-3 = Relay board

† Standard length ribbon cable is 2 ft. (610 mm). Specify in feet for other lengths.

Example: EMS25CAR4 (for 4 feet long).

EMS547 and Optional Accessories

