

Automatic Engine Controller



ASM150

- Ideal for Generators
- Solid-state Construction
- Compatible with Most New or Existing Murphy SWICHGAGE® Monitoring Systems
- Advanced, Rugged, Reliable Microprocessor Based Design
- Built-in Crank Disconnect and Overspeed Switch
- First-out Shutdown LED



Description

The ASM150 is a user friendly, solid-state, automatic engine controller. It provides basic automatic start/stop capabilities plus other features found on more sophisticated and expensive controllers.

The ASM150 operates from 12 or 24 volt battery. It includes features such as selectable crank and rest cycles, sensing circuit for crank disconnect and overspeed, overcrank, and re-crank protection on false starts. Four LEDs indicate first-out shutdown for: low pressure, high temperature, overcrank and overspeed. A fifth LED indicates engine running.

Advanced microprocessor circuitry gives the ASM150 high reliability and flexibility.

The ASM150 is compact and housed in a corrosion-resistant case. It mounts flush in a panel and requires very little room. Ideal for small generator or engine panels.

Features

- Compact design
- Optically Isolated Noise Resistant Inputs
- Re-Cranks Engine on False Starts
- Adjustable Lockout Time Delay During Startup
- Two (2) Element Adjustable Speed Switch
- Outputs for Cranking and Fuel Valve
- Outputs for Fault Annunciation
- Lamp Test Terminal

Specifications

Power Input: 12 or 24 VDC.

Operating Temperature:
-40 to 185°F (-40 to +85°C).

Inputs: Ground or positive inputs for high temperature or low pressure sensors.

Outputs

- 5 A relay for cranking and fuel valve.
- 300 mA transistor for fault annunciation.

Cycle Crank Timer: Up to 8 attempts. Re-Cranks on false starts (fixed 30 seconds).

Crank/Rest Cycle Timing
4 to 25 seconds (adjustable).

Lockout Time Delay: 1 to 25 seconds (adjustable). Locks out low oil and high temperature on start-up.

Crank Disconnect Speed Setting
From 30 to 8500 Hz.

Overspeed Trip Point Setting
From 30 to 8500 Hz.

Magnetic Pickup Input
Requires 2V rms minimum.

Shipping Weight: 1 lb. 2 oz. (0.51 kg.).

Shipping Dimensions
5 x 4-3/4 x 2-3/4 in. (127 x 121 x 70 mm).

Dimensions

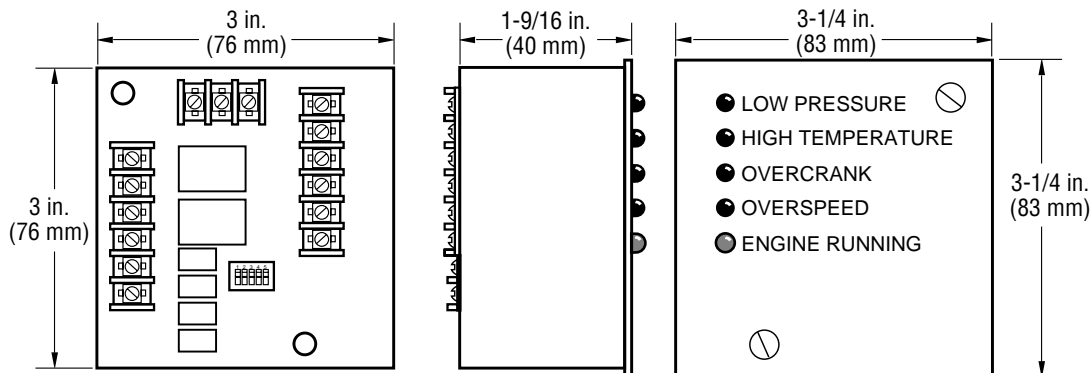

Typical Wiring Diagram

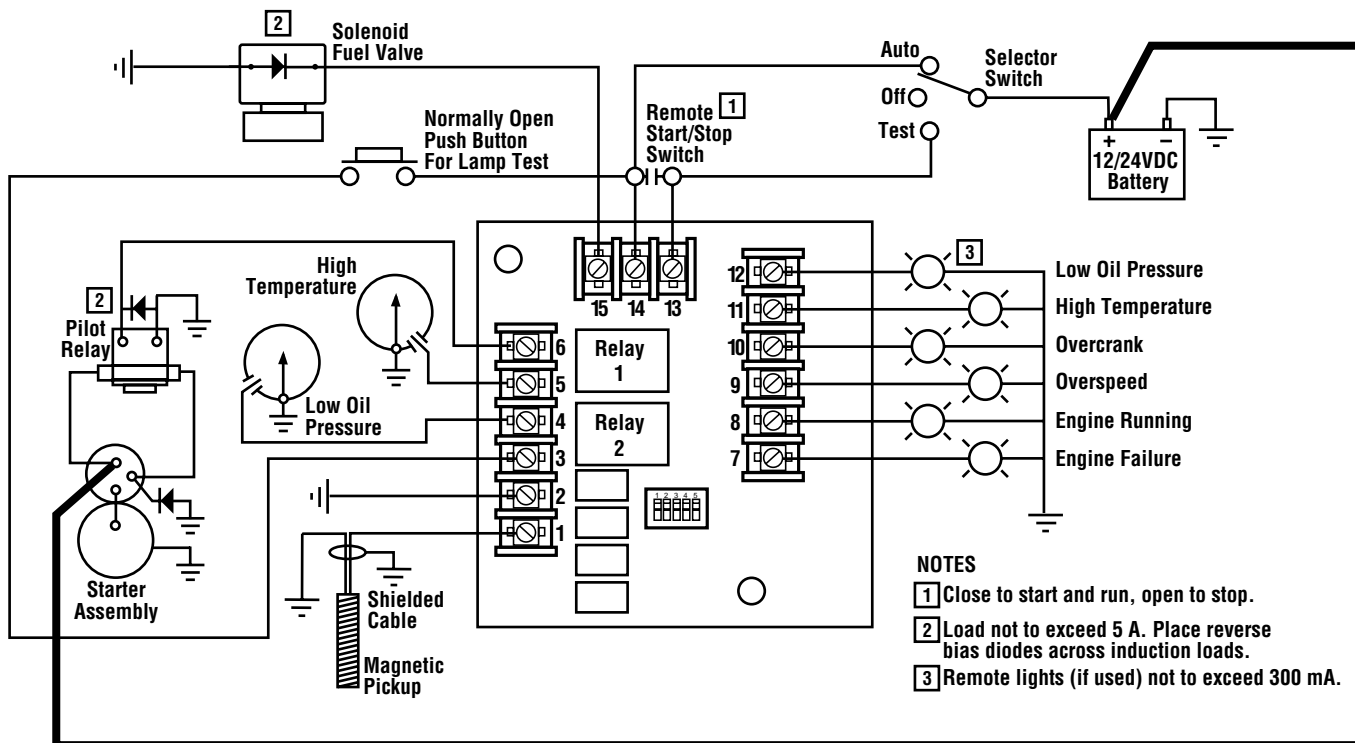

How to Order

Specify ASM150-14.



CAUTION: Certain danger to human and to equipment such as applied in a mobile or marine application may occur if some equipment is stopped without pre-warning. It is therefore, recommended that monitored functions be limited to alarm only or to alarm before shutdown in such applications.

Warranty

A two-year warranty on materials and workmanship is given with this FWMurphy product. A copy of the warranty may be viewed or printed by going to www.fwmurphy.com/warranty.asp.