

# Automatic Engine Controller



## Model EA150

- Automatic Engine Controller with Built-in SWICHGAGE® Instruments And Hourmeter
- Quick and Easy to Install
- Advanced, Rugged, Reliable Microprocessor Based Design
- Very Competitive Low Cost
- Operates On 12 or 24 Volt Systems
- First-out Shutdown LED

### Description

The EA150 Automatic Engine Controller provides you with simple—yet sophisticated, engine automation. It features basic automatic start/stop capabilities plus other features found on more sophisticated and expensive controllers—all in an easy to install panel.

The EA150 operates from 12 or 24 volt systems. It includes crank and rest cycles, sensing circuit for crank disconnect and overspeed, overcrank, and re-crank on false starts. Four LEDs indicate first-out shutdown for: low pressure, high temperature, overcrank and overspeed. A fifth LED for engine running indicates when crank disconnect occurs.

The built-in oil pressure and water temperature SWICHGAGE® instruments provide visual indication and can be set to initiate shutdown on critical pressure and temperature.

The electromechanical quartz base hourmeter can record up to 9,999.9 hours. It is housed in a shockproof case and built to be rugged and durable for a long life.

A selector switch allows you to manually select the operation sequence.

### Features

- Compact Design
- Adjustable Overspeed circuit
- Adjustable Overcrank circuit
- Adjustable Shutdown Lockout Delay
- Adjustable Crank Disconnect Setpoint
- Engine Running Indication LED
- Re-Cranks Engine on False Starts
- Advanced Microprocessor Technology Offers Reliability, Small Size, and Low Cost
- Convenient Hat Bracket design for simple engine mounting
- Built-in Hourmeter
- Temperature SWICHGAGE®
- Oil Pressure SWICHGAGE®
- Operates On 12 or 24 volt systems

### Specifications

#### Power Input

12 or 24 VDC.

#### Operating Temperature

-40 to 185°F (-40 to +85°C).

### Outputs

- 5 A relay for cranking and fuel valve.
- 300 mA transistor for engine annunciation.

#### Cycle Crank Timer

Up to 8 attempts. Re-Cranks on false starts (fixed 30 seconds).

#### Crank/Rest Cycle Timing

4 to 25 seconds (adjustable).

#### Shutdown Time Delay

1 to 25 seconds (adjustable). Locks out low oil and high temperature on start-up.

#### Crank Disconnect Speed Setting

From 30 to 8500 Hz.

#### Overspeed Trip Point Setting

From 30 to 8500 Hz.

#### Magnetic Pickup Input

Requires 2V rms minimum.

#### Shipping Weight

5 lbs. 4 ozs. (2.38 kgs.).

#### Shipping Dimensions

9-3/4 x 9-1/2 x 6 in. (248 x 241 x 152 mm).

## Sequence of Operation

**NOTE:** The following sequence is pre-programmed into the EA150 Engine Automatic.

### Operation Sequence with Panel in Auto

When the EA150 receives an automatic start signal the engine will begin to crank and the Shutdown Lockout time delay will begin. The Shutdown Lockout Delay does two functions. It allows the EA150 to disregard signals from the low oil pressure and high temperature SWITCH-GAGE® at engine start-up. Also, if the engine false starts, the re-crank will be delayed to allow the engine to stop moving before engaging the starter. If the engine fails to start after the set number of crank and rest attempts, the EA150 will indicate an overcrank condition by turning on the Overcrank LED. The engine will be locked out from any further start attempts.

**NOTE: All shutdown conditions can be reset by moving the selector switch into the OFF position and back into the AUTO position.**

Once Crank Disconnect speed is reached the Engine Running LED will turn on. The engine will also run at full governed speed while in operation. If the engine speed exceeds the Overspeed setpoint, the EA150 will initiate an engine shutdown and Overspeed LED will turn on. The engine will be locked out from any further start attempts.

If a low oil pressure or high temperature condition occurs while the engine is running, the EA150 will shutdown the engine and the appropriate LED will turn on. The engine will be locked out from any further start attempts.

**NOTE:** The Shutdown Lockout Delay must have expired to get a shutdown on low oil pressure and high temperature.

### Operation Sequence with Panel in Test

When the selector switch is placed in the TEST position, an automatic start signal is simulated. Therefore, the controller will operate the same as it does in AUTO. However, it will continue to run as long as there are no signals from monitored conditions or until the selector switch is moved to the AUTO or OFF positions. Keep in mind, it will still shutdown the engine if a monitored condition occurs such as low oil pressure or high temperature.

## Dimensions

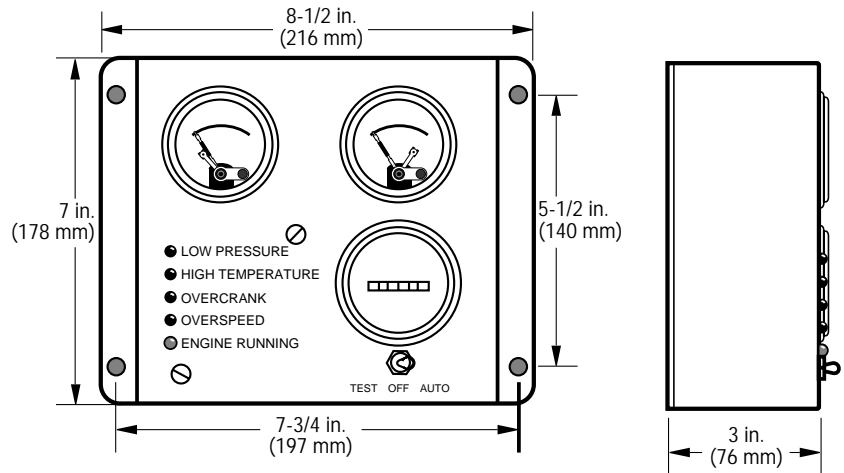

## Typical Wiring Diagram

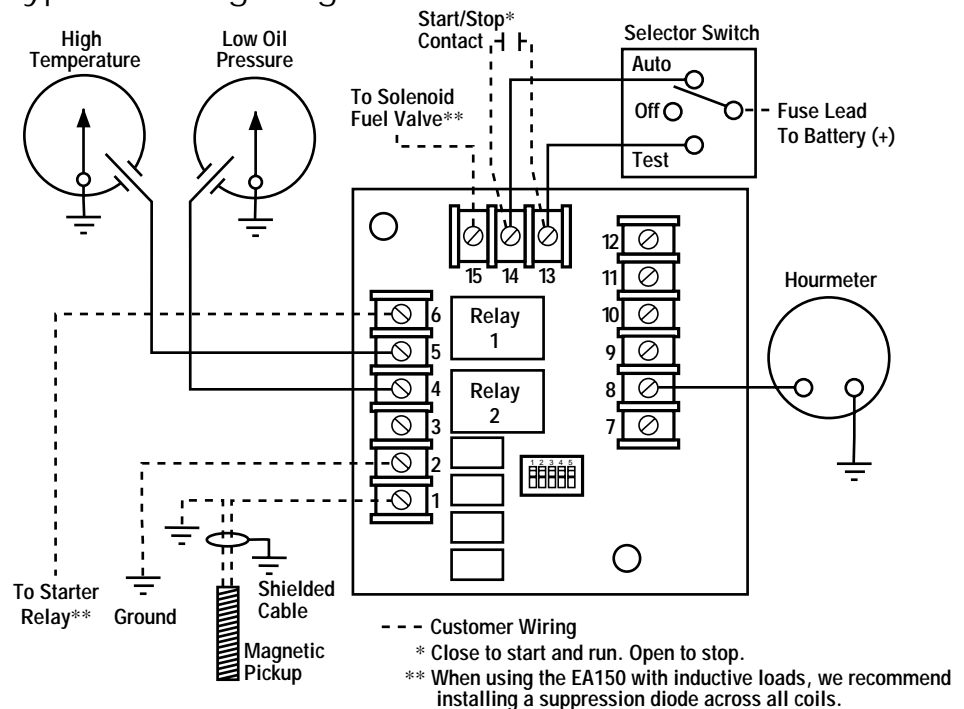

## How to Order

Specify EA150.

## Warranty

A two-year limited warranty on materials and workmanship is given with this Murphy product. Details are available on request and are packed with each unit.