

Typical Wiring Tech Sheet for Magnetic Switches and TATTLETALE® Annunciators

WIR-97020B
Revised 10-01
Section 25
(00-02-0257)

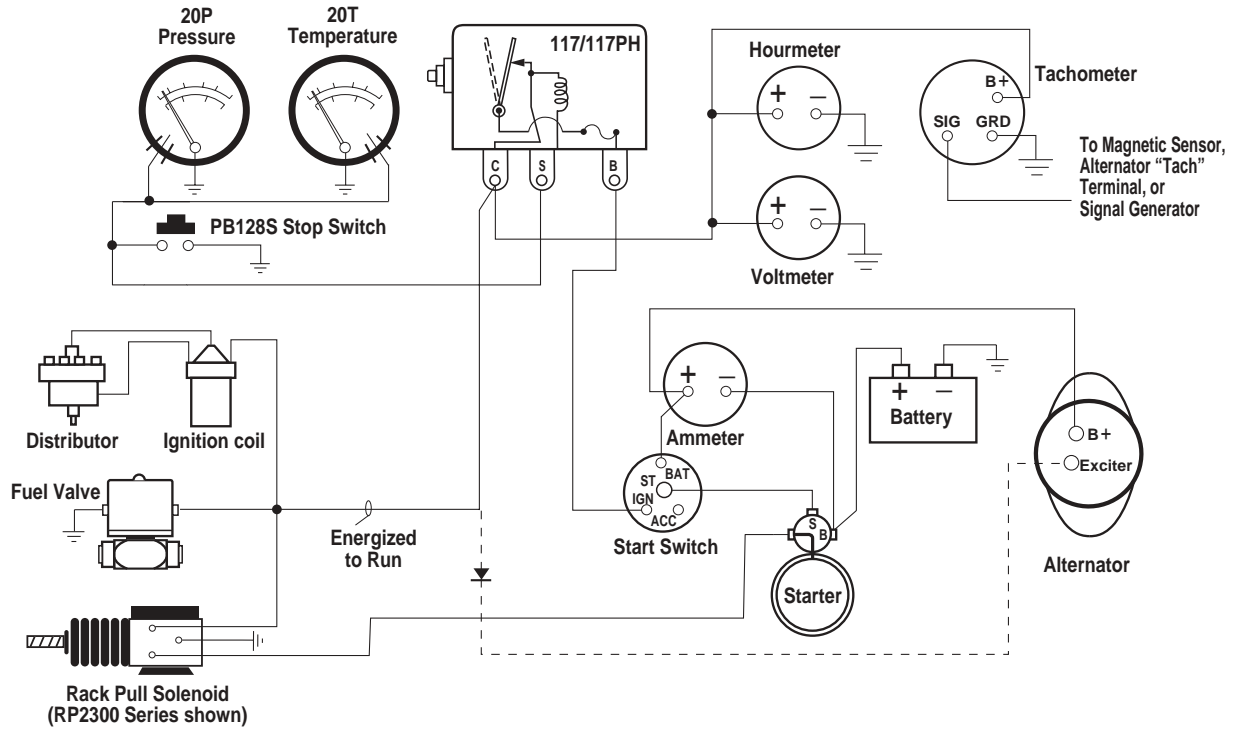

Typical Wiring Diagram with 117/117PH Magnetic



Typical Wiring Diagram with MS2100 TATTLETALE®

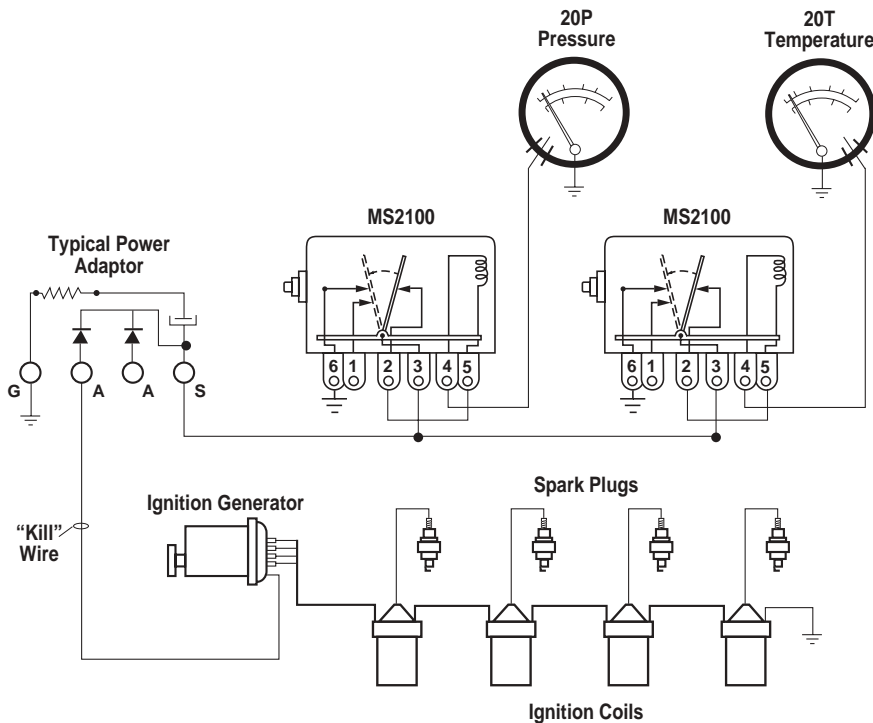

Typical Wiring with 518PH TATTLETALE®

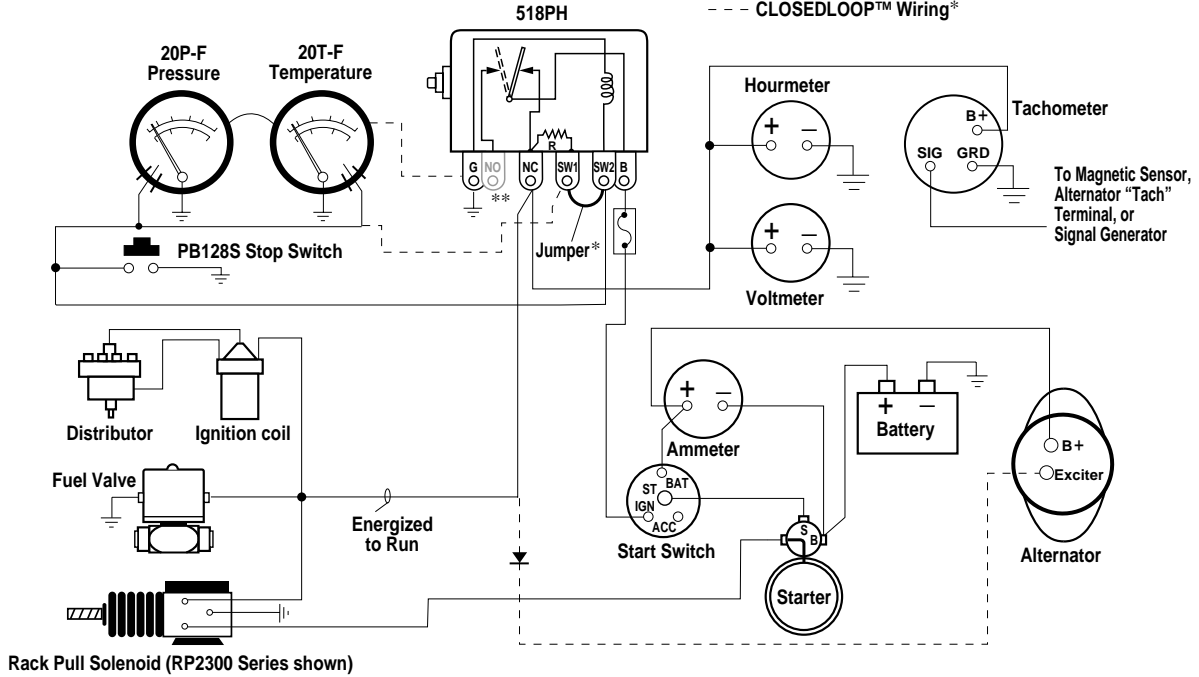

*Jumper is to be removed when connecting a CLOSEDLOOP™ circuit.
 **Normally Opened terminal is available on the 518APH model.

Typical Wiring Diagram with 760A and 761APH

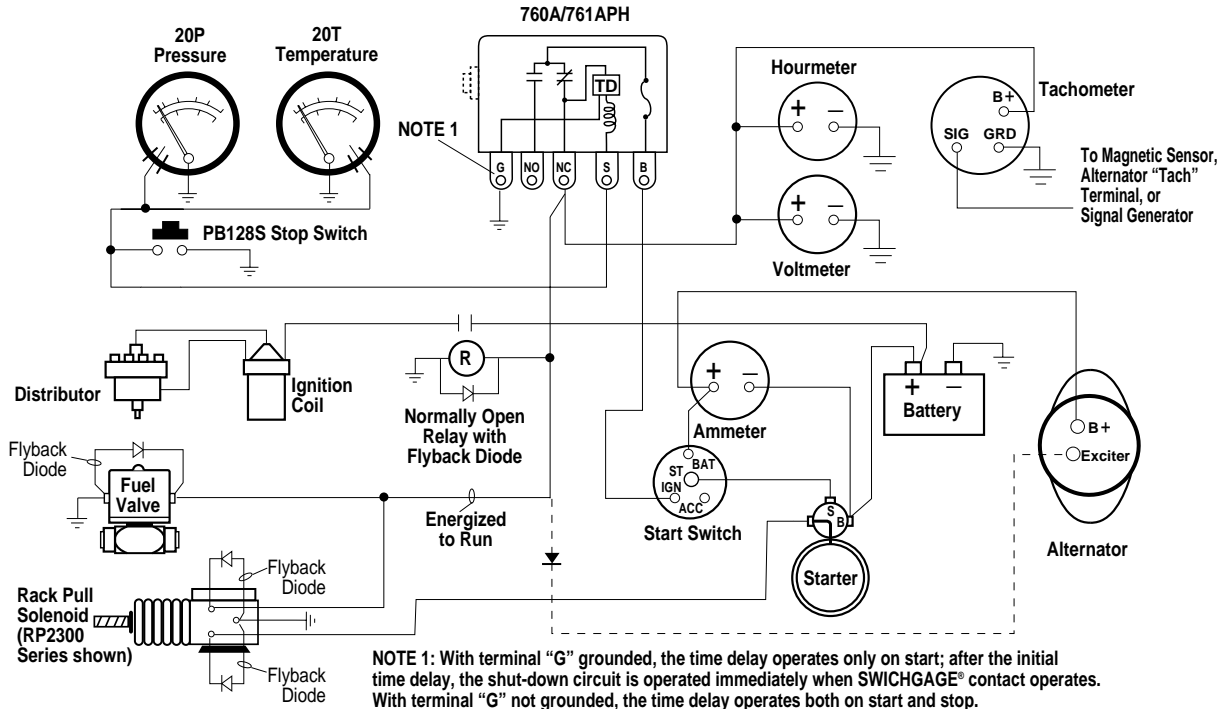

NOTE 1: With terminal "G" grounded, the time delay operates only on start; after the initial time delay, the shut-down circuit is operated immediately when SWICHGAGE™ contact operates. With terminal "G" not grounded, the time delay operates both on start and stop.