



## Replacement Cross Reference

This magnetic switch replaces the models shown in the left hand column. Non "PH" models (e.g. 307, 307CD, 274, etc.) are discontinued and are replaced by the new models shown in this Cross Reference. Note the mounting differences between old "PH" and old "non-PH" models. All new models have the same mounting as the old "PH" models. A mounting template is included in the unit carton for the new model. Otherwise, operation is the same for old and new models. Terminal crossover letters/numbers are shown for each model. Note in some cases terminal(s) are not used with the new model. Also note that a jumper (provided in the hardware package) may also be required.

ed in the unit carton for the new model. Otherwise, operation is the same for old and new models. Terminal crossover letters/numbers are shown for each model. Note in some cases terminal(s) are not used with the new model. Also note that a jumper (provided in the hardware package) may also be required.

**External wiring shown is typical for intended applications.**

Discontinued	Terminal Crossover		Replacement
	<b>221PH</b>  <b>E</b> <b>C</b> <b>B</b> <b>D</b> <b>S</b>	<b>Changes to</b> 	<b>MS2110</b>  <b>1</b> <b>2</b> <b>3</b> <b>4</b> <b>5</b>  
	<b>169PH</b>  <b>G</b> <b>C</b> <b>S</b> <b>B</b>	<b>Changes to</b> 	<b>MS2110</b>  <b>6</b> <b>1</b> <b>3</b> <b>4</b>  
	<b>274</b> <b>274PH</b>  <b>C</b> <b>S</b> <b>B</b>	<b>Changes to</b> 	<b>MS2110</b>  <b>1</b> <b>4</b> <b>3</b>  

### "non-PH" Mounting

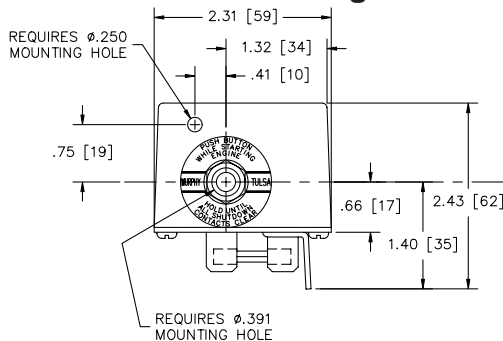

### "PH" Mounting

