

Shock and Vibration Control Switch

VS-94092B
Revised 03-03
Catalog Section 20
(00-02-0077)

FWMurphy



VS94 Model

VS94 Model

- NEMA 4X/IP66 Enclosure (CSA Types 4 & 12)
- Protects Your Equipment from Excessive Shock or Vibration
- Fine Adjustment to Precisely Select the Degree of Sensitivity
- Reset from a Remote Location (Optional)
- Time Delay to Override Trip Operation at Start-up (Optional)
- Space Heater to Prevent Moisture Condensation Inside the Unit (Optional)

Description

VS94 Series is an electro-mechanical device designed to protect equipment from damaging shock or vibration. This sensitive mechanism can detect excessive shock or vibration and shutdown the equipment before further damage occurs. A set of contacts is held in a latched position through a magnetic latch mechanism. As the level of shock or vibration increases an inertia mass exerts force against the latch arm and forces it away from the magnetic latch causing the latch arm to separate and to operate the contacts. Sensitivity is obtained by adjusting the amount of air gap between the magnet and latch arm plate.

The VS94 Series is housed in a NEMA 4/4X glass filled polyester enclosure and has a base mount. It is for applications in non-hazardous locations.

VS94 models are rated up to 480 VAC.

(See the How to Order section on back page for models and options available.)

Applications

Applications for the VS94 include all stationary types of machinery or equipment where excessive shock/vibration can be damaging or poses a threat to normal operations such as in:

- Cooling fans
- Engines
- Pump jacks
- Compressors
- Pumps
- Rotating and Reciprocating Machinery

Features

- Electromechanical Design
- Detects Shock or Vibration in Three Planes of Motion
- NEMA 4/4X (CSA types 4 and 12) Weather-proof Enclosure
- Reliable Magnetic Latch Feature
- Micro Fine, Easy-to-Adjust Sensitivity Adjustment
- Manual Reset (Standard)

- Remote Reset (Optional)
- Adjustable Start-up Time Delay (Optional)
- Space Heater Circuit to Prevent Housing Moisture Condensation (Optional)
- Two (2) versatile SPDT snap-switches rated up to 480 VAC.

Options

Remote Reset

This option of the VS94 includes a built-in electric solenoid which allows reset of tripped unit from a remote location. Available for 115 VAC or 24 VDC.

Time Delay

Overrides trip operation on start-up. The time delay option is field-adjustable from 5 seconds up to 6-1/2 minutes with an easy-to-adjust 20-turn potentiometer. Available for 115 VAC or 24 VDC.

Space Heater

This optional circuit prevents moisture condensation inside the VS94 housing.

Specifications

Case: Polyester fiberglass reinforced; NEMA type 4X; IP66; CSA types 4 and 12.

Conduit Fitting: 3/4 NPT conduit fitting connection.

Normal Operating Ambient Temperature:

0 to 140°F (-18 to 60°C).

Snap-switches: 2-SPDT snap acting switches; 5A @ 480 VAC; 2A resistive, 1A inductive, up to 30 VDC.

Range adjustment: 0 - 7 G's; 0 - 100 Hz / 0.100 in. displacement.

Space Heater (optional):

| Option | Operating Current |
|--------|-------------------|
| H15 | .023 A @ 115 VAC |
| H24 | .12 A @ 24 VDC |

Remote Reset (optional):

| Option | Operating Current |
|--------|-------------------|
| R15 | .17 A @ 115 VAC |
| R24 | .36 A @ 24 VDC |

Time Delay (optional):

| Option | Operating Current | Standby Current |
|--------|-------------------|-----------------|
| T15 | .360 A @ 115 VAC | .01 A @ 115 VAC |
| T24 | 1.15 A @ 24 VDC | .01 A @ 24 VDC |

Time Delay/Remote Reset: Adjustable 20-turn potentiometer from 5 seconds to 6-1/2 minutes (15 seconds per turn approximately).

Shipping Weight: 4.35 lb. (2 kg.)

Shipping Dimensions: 9 x 8 x 4-11/16 in. (229 x 203 x 119 mm)

How to Order

To order your VS94 model use the diagram below.

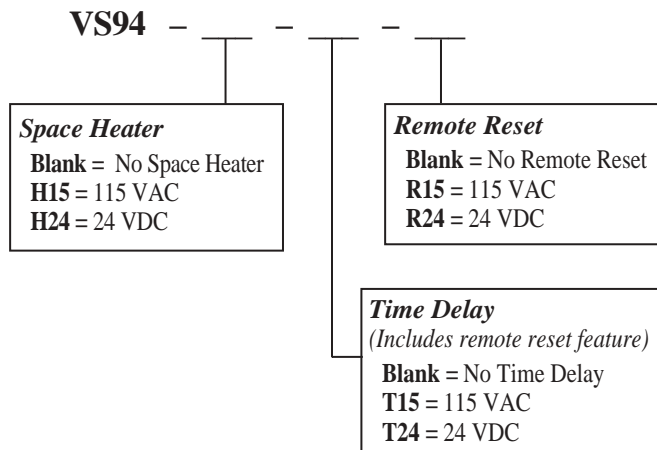

Dimensions

VS94 Series Models

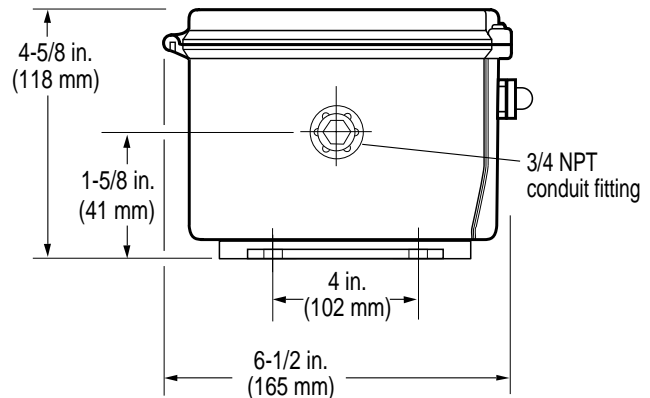
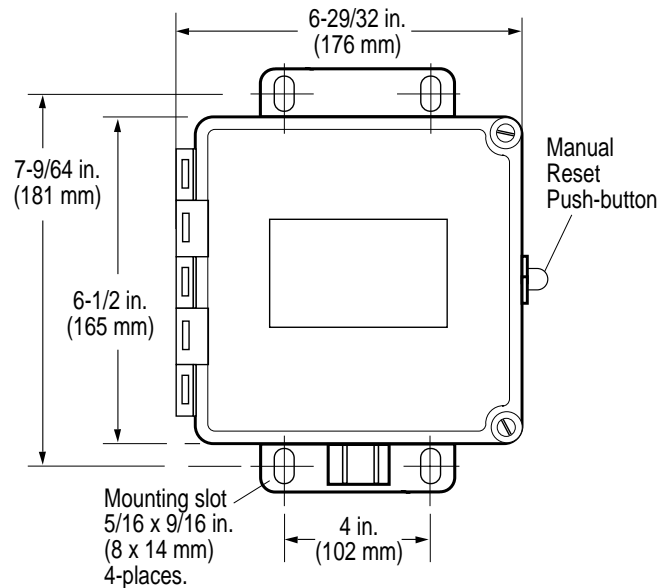

Warranty

A two-year limited warranty on materials and workmanship is given with this Murphy product. Details are available on request and are packed with each unit.