

Digital Tachometer and Hourmeter With Adjustable Overspeed Set Point



Model MTH6

- Tachometer and Hourmeter With Overspeed Shutdown or Alarm Switch
- 3-1/2 Inches (89 mm) Diameter Dial
- Reads RPM Data from a Magnetic Pickup or Battery Charging Alternator
- Powered by 8 to 40 VDC
- Large 5-Digit LCD Display
- Maintains Hours Count When Power Is Lost
- Front Panel Programming
- Hours Can Be Reset to Zero

Description

This microprocessor-based digital tachometer and hourmeter with a built-in overspeed switch is highly accurate and dependable. It measures speed and running hours and can give an alarm or shut down the engine on overspeed.

The MTH6 case is polycarbonate, and its dial measures 3-1/2 in. (89 mm) in diameter.

RPM data for the tachometer and overspeed switch is supplied by a magnetic pickup or battery charging alternator. The magnetic pickup is installed into the flywheel housing of an internal combustion engine. The starter ring gear acts upon the magnetic pickup to generate a voltage pulse each time a gear tooth passes the end of the sensor.

Applications

- Industrial Engines
- Generators
- Compressors
- Oil Field Equipment
- Marine Engines
- Vehicles
- Farm Equipment
- Construction Equipment

Basic Operation

During normal operation, the MTH6 displays RPM. Its five-digit, liquid crystal display is updated every second. When the MTH6 is displaying hours and a speed signal is present, the far left digit and decimal point will flash indicating the hourmeter is operating.

The overspeed set point and running hours can be viewed by manipulating three membrane switches located on the MTH6 front panel.

When the overspeed set point is met an LED, also located on the front panel, lights.

Easy-Calibration

The MTH6 calibration is simple. The operator enters the number of pulses per engine revolution and the overspeed set point value using the membrane-switches located on the front of the MTH6.

Specifications

Power Requirements:
8-40 VDC (12, 24 or 32 VDC systems).

Maximum Current:
12 VDC: 0.011 A, backlight Off;
0.025 A, backlight On.

24 VDC: 0.008 A, backlight Off;
0.015 A, backlight On.
32 VDC: 0.007 A, backlight Off;
0.010 A, backlight On.

Operating Temperature: -4° to 158°F
(-20° to 70°C).

Storage Temperature: -40° to 185°F
(-40° to 85°C).

Case: 1018 Polycarbonate/Polyester blend.
Mounting Hole Dim.: 3-3/8 in. (86 mm) Dia.

Speed Input: 4.5 Vrms minimum.

Overspeed Switch Rating: 2 A, 50 VDC.

Overspeed Range: 0 to 9000 RPM.

Pulses per Revolution: 4 to 255.

Tachometer Range: 0 to 65,535 RPM.

Tachometer Accuracy: ±1% of the display reading or -2 RPM whichever is greater.

Input Frequency Range: 25 Hz to 20 kHz.

Hourmeter Range: 0 to 99999 hrs.

Hourmeter Resolution: ±0.1 Hour up to 9999.9; ±1 hour 10,000 and up.

Reset Hourmeter: Apply temporary ground to terminal #5 to reset hours to zero.

Shipping Weight: 14 oz. (435 g).

Shipping Dimensions: 5-1/2 x 5-1/2 x 5-1/2 in. (140 x 140 x 140 mm).

Dimensions

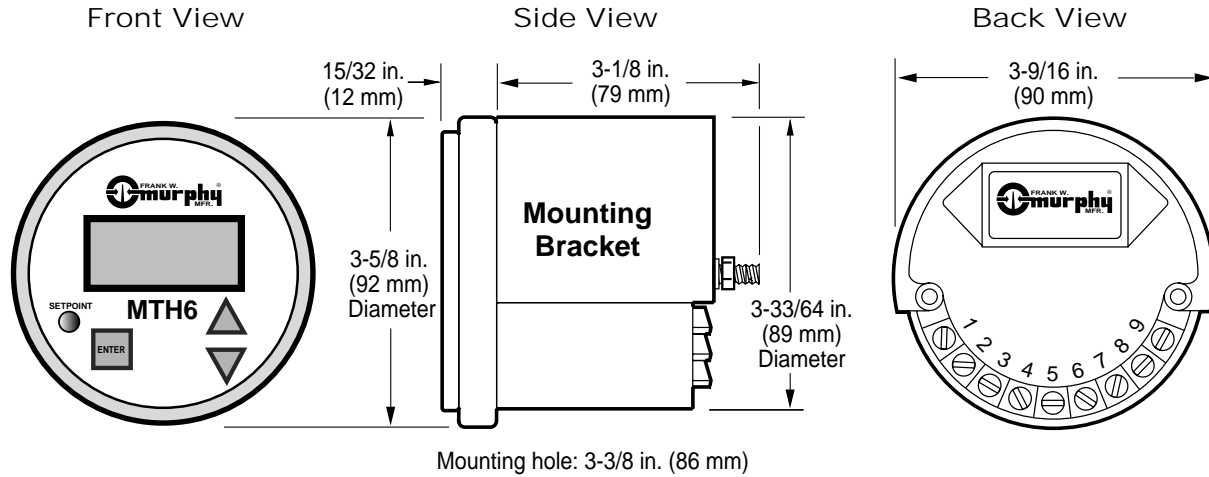

How to Order

Order by model designation:

MTH6 - -

Face Plate:

- 1 = White Background
- 2 = Black Background

Bezel:

- Blank = Bright Stainless
- A = Black Stainless

Warranty

A two-year limited warranty on materials and workmanship is given with this Murphy product. Details are available on request and are packed with each unit.

Typical Wiring Diagram

