

Lube Level Maintainer



Model LM2000/LM2000S

- Eliminates under/overfill due to “human error”
 - See oil level and condition without shutting down
 - Simple installation
 - Automatically maintains lube level
 - Low level switch
 - Positive sealing Thumb-Valve™
 - Heating loop and special mounting capabilities*
- Not intended for use with fuel**

Description

Murphy LM2000 model maintains the crankcase oil level of an engine, pump or compressor. Adjusted to the correct *running-oil-level*, the LM2000 will replenish oil as it is used. An integral, low-level switch will alarm and/or shutdown the equipment if supply oil is lost and the equipment continues to use oil.

Application

The LM2000 maintains oil level on any size engine, but is recommended for small to medium volume applications and installations that require a 3-wire, snap-action switch.

How the LM2000 Maintains Levels

As crankcase oil level drops, the LM2000 float also drops and opens the Thumb-Valve™. This allows oil to flow from the supply tank, through the LM2000, and into the crankcase. When proper level is attained in the crankcase, the LM2000 float rises, causing the Thumb-Valve™ to close off further oil flow.

The simple and unique Thumb-Valve™ is non-clogging and provides a positive, leak-free seal.

Flow rate through the 1/8 in. (3 mm) orifice is sufficient to allow crankcase refill through the LM2000.

Specifications

Crankcase Balance Vent Connection:

1/2 NPTF (top).

Inlet Connection: 1/2 NPTF removable screen (side).

Outlet Connection:

LM2000 3/4 NPTF (bottom)

LM2000S 2 x 3/8 NPTF (side)

1 x 3/4 NPTF (bottom)

Thumb-Valve™ Material: Viton.

Snap-switch: SPDT rating 10 A, 125 VAC; 0.5 A, 125 VDC; 10 A, 30 VDC.

Wire leads: 18 AWG x 24 in. (609 mm) length.

Conduit Connection: 1/2 inch conduit (female, top).

Case: Die cast aluminum

Lens: Clear “Frog Eye” non-staining, high impact, high temperature nylon; UV and heat stabilized.

Dial: High visibility white background with green and white “index” lines for normal level indication.

Maximum Inlet Pressure: 9.50 psi/25 ft. oil (head pressure).

Maximum Case Pressure: 15 psi (103 kPa).

Maximum Differential: 2 in. (51 mm) between running and stopped.

Maximum Ambient Temperature: 250°F (121°C).

Float: Brass

Flow Rates: SAE 40 motor oil @ 32°F (0°C) with 2 ft. head pressure: 0.5 GPH (1.9 LPH) (1/8” orifice).

NOTE: Friction losses due to piping not considered.

Optional Vent Fitting Kit: 15000954

Kit sold separately—includes the following items:

Quantity	Description
1	Tubing vent (15050202).
1	1/4 x 1/2 NPT Connector (85030447).

Optional Hose Kit: 15000355

Quantity	Description
1	1/2 in. (13 mm) I.D. x 3 ft. (914 mm) long hose (89020202)
1	1 in. (25 mm) I.D. x 3 ft. (914 mm) long hose (89020203)
2	1/2 in. (13 mm) worm gear clamp (00003502)
2	1 in. (25 mm) worm gear clamp (00003503)
2	1/2 NPT x 1/2 in. (13 mm) barbed fitting (89080801)
2	3/4 NPT x 1 in. (25 mm) barbed fitting (89081001)

Thumb-Valve Operation

As the equipment uses oil, the float falls, providing immediate level compensation. At FULL position, the float holds the valve closed. If the clean oil supply is depleted and oil level continues to fall, the low level switch will operate an alarm or equipment shutdown.

Thumb-Valve™ Operation (Simplified)

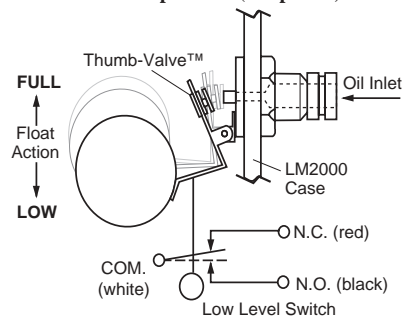

* Contact the factory for detailed information.
 See back page for telephone and fax.



Dimensions

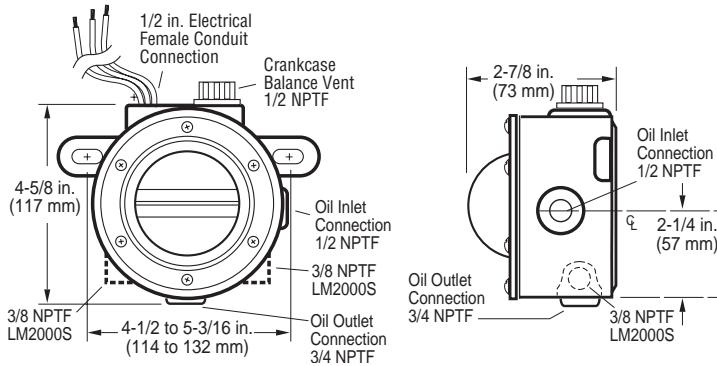

How to Order

Specify model **LM2000**

LM2000S

Accessories (Specify part number)

Description	Part Number
Vent Fittings Kit	15000954
Hose Kit	15000355
1/2NPT x 1/2 in. Hose Barbed Fitting	89080801
3/4NPT x 1 in. Hose Barbed Fitting	89081001
3/8NPTF x 1/2 in. Hose Barbed Fitting	89080601
Pipe Bracket Kit	15000238
Universal Flange Kit	15010224

LM2000/LM2000S Shipping Dimensions:

9 x 5-1/2 x 6 in. (229 x 140 x 152 mm).

LM2000/LM2000S Shipping Weight:

3 lbs. 6 oz. (1.5 kg)

Mounting Brackets with Hardware

Murphy offers two mounting brackets for the LM2000. The 15000238 Pipe Bracket Kit fits a 7/8 in. (22 mm) diameter pipe (see typical installation below). The 15010224 universal Flange Kit allows various mounting methods.

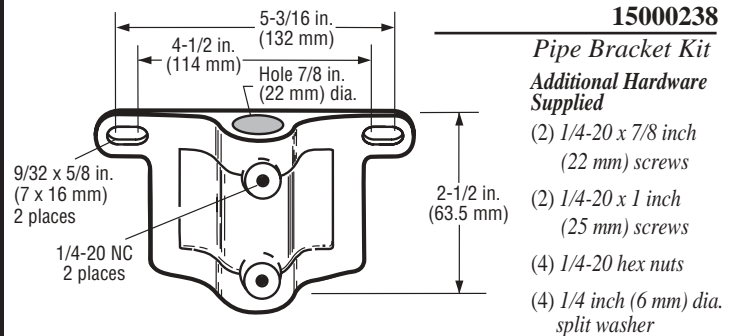

15010224

Universal Flange Kit

Additional Hardware Supplied

- (2) 1/4-20 x 1-1/4 inch (32 mm) bolts
- (4) 1/4 inch dia. flat washer
- (2) 1/4-20 hex nuts
- (2) 5/16-18 x 1-1/4 inch (32 mm) bolts
- (4) 5/16 dia. flat washer
- (2) 5/16-18 hex nuts

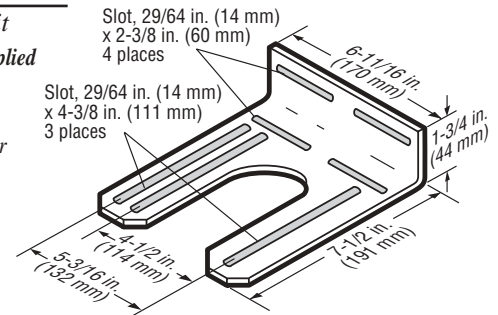

Warranty

A two-year warranty on materials and workmanship is given with this FWMurphy product. A copy of the warranty may be viewed or printed by going to www.fwmurphy.com/warranty.asp.

LM2000 Typical Installation

