

Level Controls for Scrubbers

FWMurphy

Model L1200 Float Operated Electric



L1200 Series

Patents 3970099, 4505288, 4573489

- BUOYGLAS™ Float Operates to 0.5 Specific Gravity
- Stainless Steel Models Meet NACE Requirements and Carry Canadian Registration Numbers
- Models Rated for 2000 psi (13.8 MPa) [138 bar] Vessels
- Models Listed for Class I, Division 1 Locations

Model L1200N Float Operated Pneumatic



L1100 and L1200 Series Level Switches

These float operated level switches are available in electric and pneumatic models. They are primarily designed for high level applications but models are available for low level. Electric models are listed for Class I, Division 1, Groups C & D hazardous locations. Models are available in all stainless steel to NACE standard MR-01-75 for direct exposure to H₂S service. These level switches have screw-in connections for direct installation or an optional external float chamber is available for the L1200 series high pressure versions. The high pressure versions of both L1100 and L1200 series are rated for 2000 psi (13,8 MPa) [138 bar] operating pressure. **See the specifications sections of this bulletin for further details.**

NOTE: All stainless steel versions of L1100, L1200, L1200N, L1200NDVO, and L1200NDVOR series carry Canadian Registration Number OF1476.2.

Model L1200NDVOR Float Operated Pneumatic with Dump Valve Operator, Pressure Regulator and Gage



Application: L1100 and L1200 Series

Designed primarily for gas compressor scrubber level. Low pressure models can be used anywhere level switching of a non-pressurized vessel is required. Electric models are typically used for high level shutdown of the engine or electric motor, while pneumatic models operate vessel dump valves such as Murphy DV-series. Models designed for low level switching have been used for fuel, lube oil, hydraulic oil, etc.

DV Series Dump Valves

The DVU150, DVU175, DVU2105/2115/2120 are pneumatically controlled dump valves. These valves open and close automatically by pneumatic control from an L1200NDVO or similar dump valve operator. Diaphragm actuated, the DV series valves operate at 30-70 psi (207-483 kPa) [2.07-4.83 bar] with up to 2000 psi (13.7 MPa) [137 bar] vessel pressure. A pop up button indicates valve open/closed.

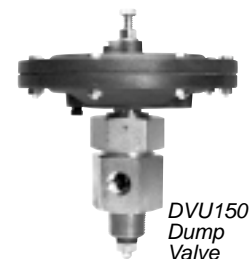

Model L1200NDVO Float Operated Pneumatic with Dump Valve Operator



Primarily engineered for compressor scrubbers, these valves can be applied to any liquids dumping job that is compatible with the valves materials, pressure limit and flow rates.

SLS02 MURPHYMATIC® Scrubber System

A complete MURPHYMATIC® system for automatic level control of condensate in scrubbers, including periodic dumping and high level shutdown, is available as a complete package from Murphy. All wetted metal parts are electroless nickel plated or stainless steel. The SLS02 scrubber system includes:

(Includes L1200, L1200NDVOR, and DVU valve)

SLS02A: Includes DVU150 valve

SLS02C: Includes DVU175 valve

SLS02BA: Includes DVU2105 valve

SLS02BB: Includes DVU2115 valve

SLS02BC: Includes DVU2120 valve

-LR: Less Regulator option

**Products covered by this bulletin comply with EMC Council directive 89/336/EEC regarding electromagnetic compatibility except as noted.

Specifications	L1100	L1111	L1150	L1200	L1250	L1200N	L1200NDVO	L1200NDVOR
Body								
• Standard: Electroless Nickel plated steel	X ^A	X ^A	X ^A	X ^B	X ^B	X ^B	X ^B	X ^B
• Optional: 316 Stainless Steel†	X ^A	X ^A	X ^A	X ^B	X ^B	X ^B	X ^B	X ^B
Pressure Rating								
• 15 psi (103 kPa) [1.03 bar] Polyethylene Float			X		X			
• 1500 psi (10.3 MPa) [103.42 bar] Stainless Float	X	X		X		X	X	X
• 2000 psi (13.8 MPa) [138 bar] BUOYGLAS™ Float	X	X		X		X	X	X
Temperature Rating								
• Standard: -20/175°F (-29/79°C)			X		X			
• Standard: -20/300°F (-29/149°C)	X	X		X		X	X	X
• Optional: -20/400°F (-29/204°C)*	X			X		X	X	X
Specific Gravity								
• Standard: 0.5 with BUOYGLAS™ float	X	X		X		X	X	X
• Optional: 0.65 with 304 Stainless Steel†	X			X		X	X	X
• Standard 0.73 Polyethylene Float			X		X			
Electrical								
• Standard SPDT: 5 A @ 125/480 VAC (see p. 3 for full ratings)	X	X	X	X	X			
• Optional DPDT: 10 A @ 250 VAC (see p. 3 for full ratings)	X	X	X	X	X			
Wire: 18 AWG x 36 in. (1.0 mm ² x 914 mm)	X	X	X	X	X			
O-Rings: Viton	X	X	X	X	X	X	X	X
Valve: Two-way snap-action vent type								
• 1/8 in. (3 mm) orifice w/Viton "A" seat								
• 1/8 NPT inlet; 1/4 NPT outlet								
• 30-70 psi (207-483 kPa) [2.07-4.83 bar] operating pressure						X	X	X
Dump Valve Operator: Operates Murphy DV Series dump valves or similar.							X	X
Pressure Regulator/Filter and Murphy 20BPG: 0-75 psi (0-517 kPa) [0-5.17 bar] pressure gauge. Maximum input 300 psi (2.07 MPa) [20.68 bar].								X
Operation: H=For high level, L=For low level	H	L	H	H	H	H	H	H

^A = 1-1/2 NPT

^B = 2 NPT

† Meets NACE standard MR-01-75 for direct exposure to H₂S service.

* Not available with DPDT snap-switch.

SLS02 Scrubber System

Patent No. 4505288

- High Level Shutdown •
- High Level Dump Valve •
- High Level Dump Valve Operator •



High Liquid Level Shutdown Switch (L1200)
Patent No. 3970099

MURPHY NU-MATIC™ Dump Valve (DVU150/175/2105/2115/2120)

MURPHY NU-MATIC™ Dump Valve Operator (L1200NDVOR)
Patent No. 3970099

SLS02 System Operation

As condensate rises in the scrubber, the float on the L1200NDVOR rises and trips its pneumatic valve. The valve opens allowing pressure to enter the dump valve pilot chamber. Once the pressure enters the pilot chamber it forces the diaphragm and valve stem forward thus opening the valve seat and releasing condensate through the valve stem and out the drain. As the condensate level drops, the L1200N pneumatic valve closes to shut off the pressure to the dump valve causing it to close.

If for any reason the condensate continues to rise beyond normal dump levels, the L1200 operates the alarm and/or shuts down the equipment.

The MURPHYGAGE® and Filter/Regulator on the L1200NDVOR helps keep the control pressure clean and dry. It also allows operator to adjust pressure to recommended level.

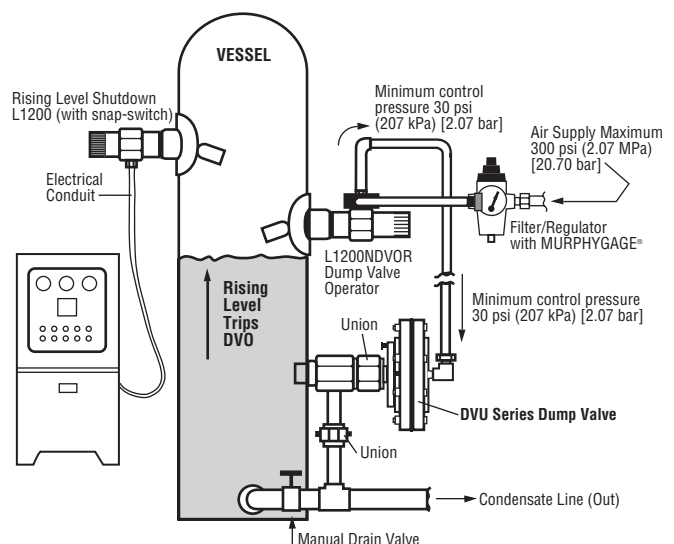

Dimensions

L1100 and L1200

Note 1:

L1100: 1-1/2 NPT
L1200: 2 NPT

Note 2: 1-9/16 (40 mm)

SF option:

L1100: 1-1/2 (38 mm)
L1200: 1-3/4 (44 mm)

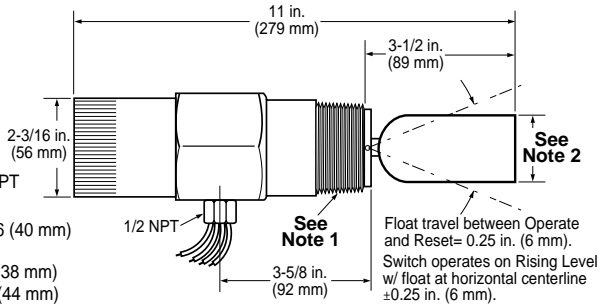

L1111

Note: 1-9/16 (40 mm)

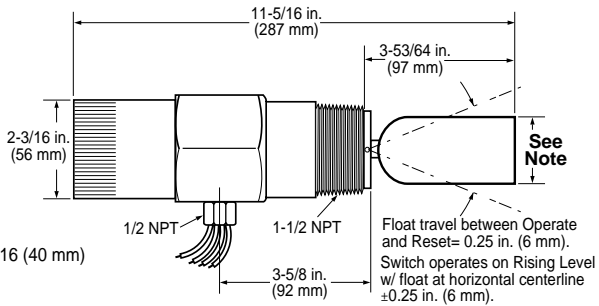

L1150 and L1250

Note 1: L1150: 1-1/2 NPT
L1250: 2 NPT

Note 2: L1150: 1-1/2 in. (38 mm)
L1250: 2 in. (51 mm)

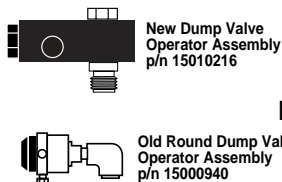
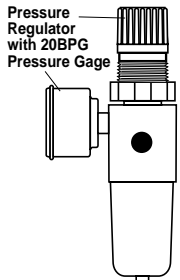
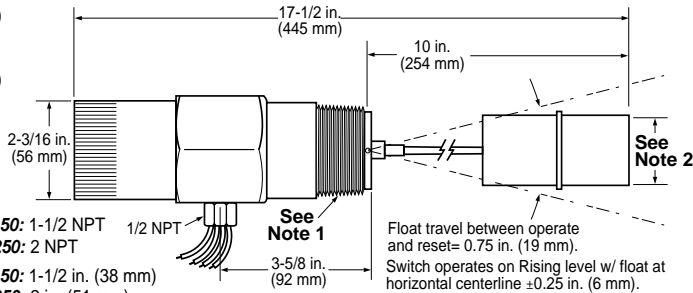

L1200N, L1200NDVO and L1200NDVOR with Dump Valve Operator, Pressure Regulator and Gage

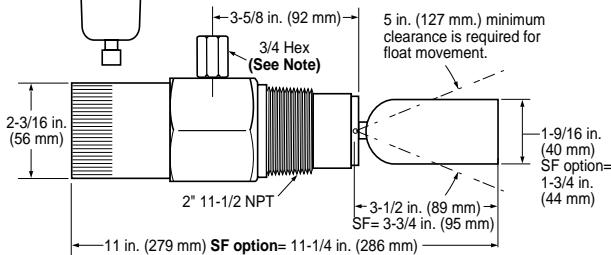

Note: For use only with Old Round Dump Valve Operator Assembly (15000940).

Wiring

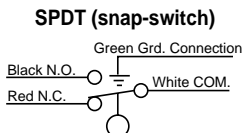

Switch Rating: 5 A @ 125-250- 480 VAC
1/2 A @ 125 VDC
1/4 A @ 250 VDC
2A @ 6-30 VDC Resistive
1A @ 6-30 VDC Inductive

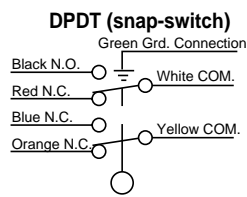

Switch Rating: 10 A @ 125-250 VAC
1/2 A @ 125 VDC
1/4 A @ 250 VDC
10 A @ 6-24 VDC Inductive/Resistive

Accessories

Adaptor Bushing 55050617 for DVU150 and DVU175

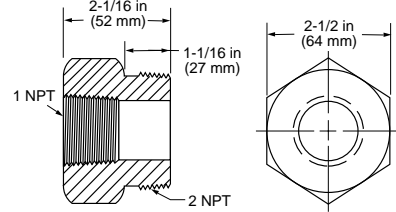

Material: 2-1/2 Hex bar stock C.R.S

Float Chamber 15051098

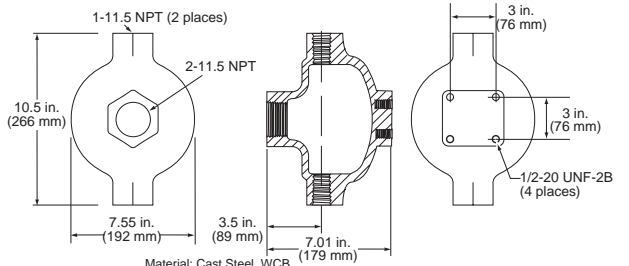

Material: Cast Steel, WCB

Operating Pressure: 2000 psi (13.8 MPa) [138 bar]
Operating Temperature: 400°F (204°C)

Typical L1200/L1200N Float Chamber Installation

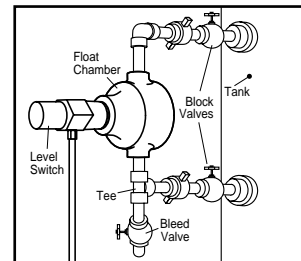

Weld Collar 15050375 (use with L1200 only)

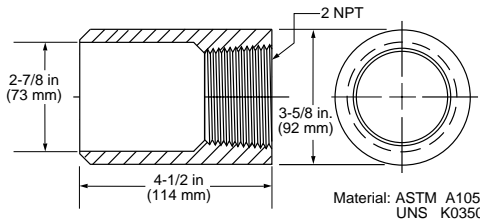

Material: ASTM A105-2
UNS K03504

Typical L1200 Weld Collar Installation

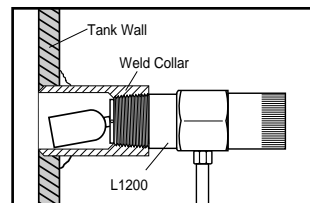

Operating Pressure: 2000 psi (13.8 MPa) [138 bar]
Operating Temperature: 400°F (204°C)

Float Shaft Extension 15000892

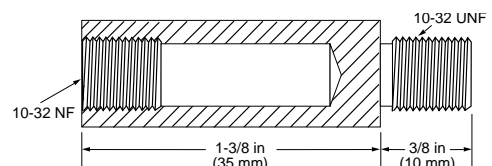

Material: AISI 304, UNS-S30400

NOTE: The extension is used with the L1100 and L1200 only. One extension is supplied with each unit. Use of additional extensions is not recommended as they reduce the ability of the unit to operate for the stated specific gravity.

How to Order

L1100 and L1200 Series

Build a complete model number using the diagram below. See example. See Specifications Chart on page 2 for standard and optional features.

Example model number

L1100 -

Options
D = DPDT
K = KALREZ Seals
SF = Stainless Steel Float
400 = 400°F (204°C) Service**

Base Models	
L1100*	L1100SS
L1111	L1111SS
L1150	L1150SS
L1200*	L1200SS*
L1250	L1250SS
L1200N*	L1200NSS*
L1200NDVO*	L1200NSSDVO*
L1200NDVOR*	L1200NSSDVOR*

*Stainless steel models carry Canadian Registration Number OF1476.2.

**Not available with DPDT snap-switch.

Complete SLS02 Systems

Specify

SLS02A: Includes DVU150 valve

SLS02C: Includes DVU175 valve

SLS02BA: Includes DVU2105 valve

SLS02BB: Includes DVU2115 valve

SLS02BC: Includes DVU2120 valve

-LR: Less Regulator option

Accessories (order by part number designation)

15050375: Weld collar

15000892: Float shaft extension

55050617: DVU150/DVU175 adaptor bushing 2 NPT-M to 1 NPT-F

15051098: External Float Chamber

Warranty

A two-year limited warranty on materials and workmanship is given with this Murphy product. Details are available on request and are packed with each unit.

Replacement Parts (order by part number designation)

L1100/L1200

15000893: BUOYGLAS™ float

15000894: Stainless Steel float for L1200

15000937: Stainless Steel float for L1100

15000124: SPDT snap-switch assembly

15010213: L1100 counter balance assembly

15010214: L1200 counter balance assembly

L1200N

15050420: Cam spring return

15050421: Cam

15000893: BUOYGLAS™ float

15000894: Stainless steel float for L1200N

15050453: Valve stem

15010189: Counter balance assembly

L1200NDVO and L1200NDVOR

55050621: Regulator only

05706499: 20BPG-D-75 psi (0-517 kPa) [0-5.17 bar]

15010216: DVOA assembly (New rectangular style)

15000940: DVO assembly (Old round style)

00003341: Filter for regulator

00003340: Regulator diaphragm kit

Shipping Weights

L1100: 6 lb. (2.7 kg).

L1111: 5 lb. 11 oz. (2.5 kg).

L1150: 5 lb. 4 oz. (2.3 kg).

L1200: 6 lb. 6 oz. (2.8 kg).

L1250: 6 lb. 6 oz. (2.8 kg).

L1200N: 5 lb. 5 oz. (2.4 kg).

L1200NDVO: 5 lb. 14 oz. (2.6 kg).

L1200NDVOR: 6 lb. 10 oz. (3 kg).

SLS02: 19 lb. 6 oz. (8.7 kg).

Shipping Dimensions

L1100: 14 x 5 x 3-1/2 in. (356 x 127 x 89 mm).

L1111: 14 x 5 x 3-1/2 in. (356 x 127 x 89 mm).

L1150: 14 x 5 x 3-1/2 in. (356 x 127 x 89 mm).

L1200: 14 x 5 x 3-1/2 in. (356 x 127 x 89 mm).

L1250: 14 x 5 x 3-1/2 in. (356 x 127 x 89 mm).

L1200N: 14 x 5 x 3-1/2 in. (356 x 127 x 89 mm).

L1200NDVO: 14 x 5 x 3-1/2 in. (356 x 127 x 89 mm).

L1150NDVOR: 10 x 9-1/2 x 6 in. (254 x 241 x 152 mm).

SLS02: 15 x 15 x 12 in. (381 x 381 x 305 mm).