

A20 and A25 Series Temperature SWICHGAGE®

AT-95026B
Revised 07-03
Catalog Section 10
(00-02-0039)

FWMurphy



A20T Series
shown

2 and 2-1/2 in. (51 and 64 mm) Dial

- Corrosion Resistant Polycarbonate Case
- Indicating Gage and Limit Switch
- Switch Can Activate Alarms and/or Shut Down Equipment
- Critical/High Temperature Limit Switch Is Visible and Adjustable (Most Models)
- Contact(s) Isolated From Ground

Description

The A20 Series (2 inch/51 mm dial) and the A25 Series (2-1/2 inch/64 mm dial) SWICHGAGE® models are diaphragm-actuated, temperature-indicating gages, with built-in electrical switches for tripping alarms and/or shutdown devices.

Ranges are available from 32-120°F (0-45°C) thru 300-440°F (160-220°C).

All models of these rugged, built-to-last instruments are fully sealed from the environment by the unique combination of a polycarbonate case and lens, a polished stainless steel bezel, and O-ring seals.

These vapor/pressure actuated gages feature a sealed capillary tube and a sensing bulb. When subjected to heat, the liquid in the sensing bulb changes to vapor creating pressure against a diaphragm mechanism. The diaphragm translates this vapor pressure into a mechanical gage reading.

For series A20T and A25T, the gage pointer acts as a temperature indicator and as one switch pole which completes a circuit when it touches the adjustable limit contact. Contact(s) are isolated from ground. They have self-cleaning motion to enhance electrical continuity.

Models A20TE and A25TE have internal snap-acting SPDT switches.

Gage-only models, without contacts (MURPHYGAGE®) are also available.

Applications

Applications for A20 and A25 Series temperature SWICHGAGE® instruments include: engines and equipment in Oil Field, Marine, Irrigation, Construction and Trucking industries. Monitoring Engine Coolant temperature, Crankcase Oil, Transmission Oil.

Specifications

Dial: White on black; U.S.A. standard scale is dual scale °F/°C; others available.

Case: Glass filled/Polycarbonate, corrosion-resistant; steel mounting clamp included.

Bezel: Polished stainless steel, standard; others are available.

Pointer: Tempered nickel silver; red tip.

Lens: Polycarbonate, high-impact.

Sensing Element: Beryllium copper diaphragm.

Capillary: PVC armored copper; 4 ft. (1.2 m)*
Galvanized and stainless steel armor optional.

Sensing Bulb: Copper*

Gage Accuracy: See accuracy chart, on page 2.

Maximum Temperature: See Temperature Ranges and Factory Settings table on page 2.

Adjustable Limit Contact (A20T and A25T):
SPST contact; pilot-duty only, 2 A @ 30 VAC/VDC; isolated from case ground. Normally Closed when the high limit is met. Normally Open when pointer is in normal operating range. Contacts are gold flashed silver.

Limit Contact Adjustment: *by a 1/16 in. hex wrench thru 100% of the scale.*

Wiring: A20T: Number 4 screw terminals;
A25T: Number 6 screw terminals.

Snap-Switch Rating (A20TE and A25TE):

SPDT, 3 A @ 30 VDC inductive; 4 A @ 125 VAC inductive.

Wiring: A20TE: Number 4 screw terminals;
A25TE: Number 6 screw terminals.

Unit Weight: A20 Series: 11.9 oz. (0.370 kg).
A25 Series Models: 13.3 oz. (0.413 kg).

Unit Dimensions: A20 Series: 4-3/4 x 4-3/4 x 3 in.
(121 x 121 x 76 mm). A25 Series Models: 4-3/4 x 4-3/4 x 2-3/4 in. (121 x 121 x 70 mm).

Base Models

Coolant or Oil Temperature

A20T and A25T Series SWICHGAGE®

For these models the gage pointer makes with an adjustable contact to complete a pilot-duty circuit.

A20TL and A25TL SWICHGAGE®

For use on Ford Worldwide engines. Supplied with special sensing bulb.

A20TE and A25TE SWICHGAGE®

A20TE (was A20ESR) and A25TE (was A25ESR). Models with internal SPDT snap-switches, instead of the single pole/pointer contact(s). When the switch closes on rising temperature, it becomes Set. As temperature decreases the switch Resets. Model A25TE is CSA listed for non-hazardous areas. Model A25TE-EX is CSA listed for Class I, Division 1, Groups C & D hazardous areas.



A20TABS and A25TABS SWICHGAGE®

Same as 20 and 25T with internal SPDT snap-switch for pre-alarm.

Cylinder Head Temperature

A20TH and A25TH SWICHGAGE®

A20TH (was A20TL8133) and A25TH (was A25TL8133). For use on Air Cooled engines.

Gage-Only Models

A20TG and A25TG MURPHYGAGE®

Gage without contact(s).

* For optional capillary lengths, engine adapters, sensing bulbs and range combinations, see Murphy bulletin T-8428B.

** Products covered by this bulletin comply with EMC Council directive 89/336/EEC regarding electromagnetic compatibility except as noted.

Dimensions

A20 Series Models (typical)

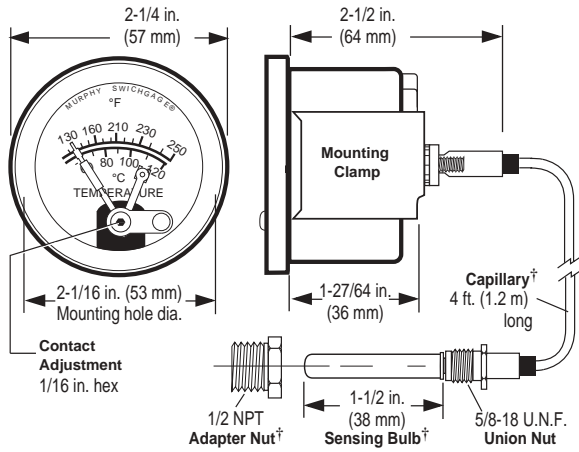

A25 Series Models (typical)

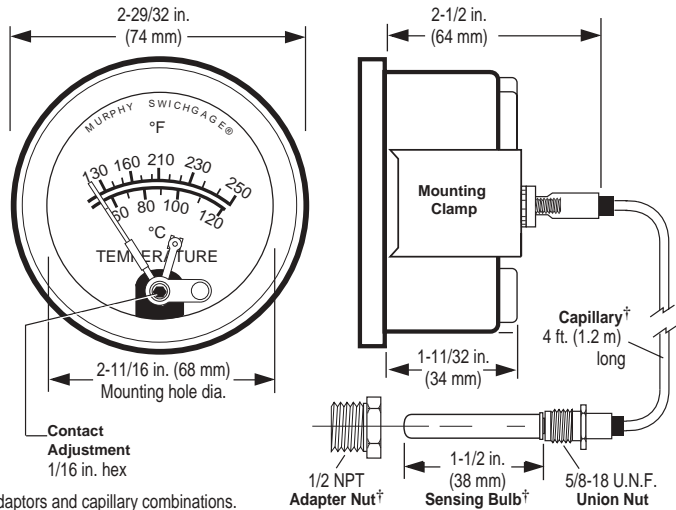

†Standard combinations. See Murphy bulletin T-8428B for optional sensing bulb, engine adaptors and capillary combinations.

Temperature Ranges and Factory Settings

NOTES

- Values in () are mathematical conversions from °F to °C—they do not reflect actual second scale range. U.S.A. standard scale is °F/°C.
- For models A20TE and A25TE; the switch trip point cannot be set at either the low or high extreme of the scale. The trip point must allow for the reset differential.
- For adjustable switch models, the trip point is adjustable **only** over the upper half of the scale.

Ranges Available		Max. Temp.	Std. Settings*		Hi/Lo Settings		20TABS and 25TABS Settings			
Dual Scale Dial °Fahrenheit (°Celsius)	Single Scale °Celsius only		°F (°C)	°F (°C)	°C only	Low °F (°C)	High °F (°C)	Alarm**		Shutdown
							°F (°C)	°C only	°F (°C)	°C only
32 – 120 (0 – 49)	—	185 (85)	110 (43)	—	32 (0)	110 (43)	100 (38)	—	110 (43)	—
32 – 160 (0 – 71)	0 – 70	215 (102)	150 (66)	66	32 (0)	150 (66)	140 (60)	60	150 (66)	66
130 – 220 (54 – 104)	45 – 100	260 (127)	210 (99)	85	160 (71)	210 (99)	200 (93)	80	210 (99)	85
130 – 250 (54 – 121)	50 – 120	310 (154)	210 (99)	97	160 (71)	210 (99)	200 (93)	95	210 (99)	100
140 – 300 (60 – 149)	60 – 140	340 (173)	275 (135)	130	200 (93)	275 (135)	265 (129)	125	275 (135)	130
160 – 320 (71 – 160)	70 – 160	370 (192)	300 (149)	150	200 (93)	300 (149)	290 (143)	145	300 (149)	150
180 – 350 (82 – 177)	—	400 (209)	330 (166)	—	240 (116)	330 (166)	320 (160)	—	330 (166)	—
300 – 440 (149 – 227)	—	500 (260)	400 (204)	—	300 (149)	400 (204)	390 (199)	—	400 (204)	—

* Standard setting for A20T, A25T, A20TE and A25TE models.

** SPDT snap-switch is the alarm switch.

Temperature Accuracy Chart

Temperature Range	Lower 1/3 of Scale	Middle 1/3 of Scale	Upper 1/3 of Scale
32 to 120°F (0 to 49°C)	± 12°F (± 6°C)	± 5°F (± 2.4°C)	± 6°F (± 3°C)
32 to 160°F (0 to 71°C)	± 20°F (± 10°C)	± 8°F (± 4.4°C)	± 7°F (± 4°C)
130 to 220°F (54 to 104°C)	± 6°F (± 3°C)	± 3°F (± 1.6°C)	± 4°F (± 2°C)
130 to 250°F (54 to 121°C)	± 9°F (± 5°C)	± 5°F (± 2.4°C)	± 4°F (± 2°C)
140 to 300°F (60 to 149°C)	± 10°F (± 5.2°C)	± 6°F (± 3°C)	± 5°F (± 2.4°C)
160 to 320°F (71 to 160°C)	± 10°F (± 5.2°C)	± 5°F (± 2.4°C)	± 5°F (± 2.4°C)
180 to 350°F (82 to 177°C)	± 12°F (± 6°C)	± 5°F (± 2.4°C)	± 5°F (± 2.4°C)
300 to 440°F (149 to 227°C)	± 9°F (± 5°C)	± 5°F (± 2.4°C)	± 4°F (± 2°C)

Maximum Temperature

MAXIMUM AMBIENT TEMPERATURE: -40° (-40°) thru 150° (66°)

RANGE	MAXIMUM PROCESS TEMPERATURE
≤250° (120°)	120% OF FULL SCALE
300° (140°)	350° (198°)
≥320° (160°)	120% OF FULL SCALE

Magnetic Switch

INDUCTIVE AND HIGH CURRENT LOADS REQUIRE THE USE OF A MAGNETIC SWITCH. The SWICHGAGE® contacts are for light-duty electrical switching to operate alarms or control devices. Murphy manufactures the Magnetic Switch for protection of the pilot-duty SWICHGAGE® limit contacts.

TATTLETALE® Magnetic Switches show the cause of shutdown for applications that include: capacitor discharge or magneto ignitions, battery systems and electric motor driven equipment. Typical wiring diagrams are shown below.

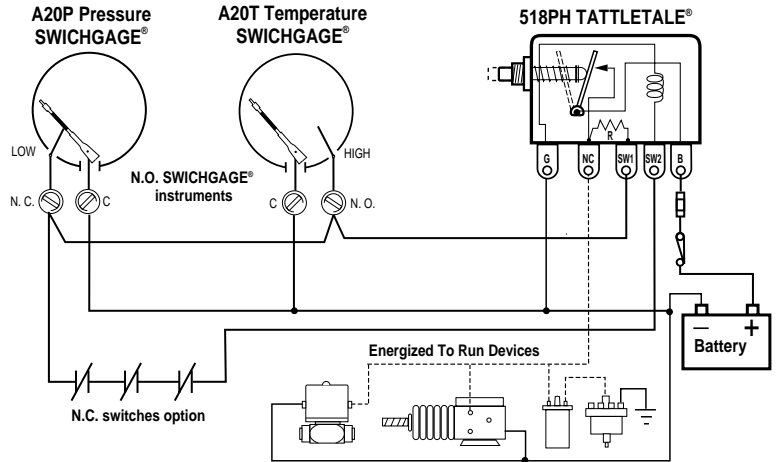
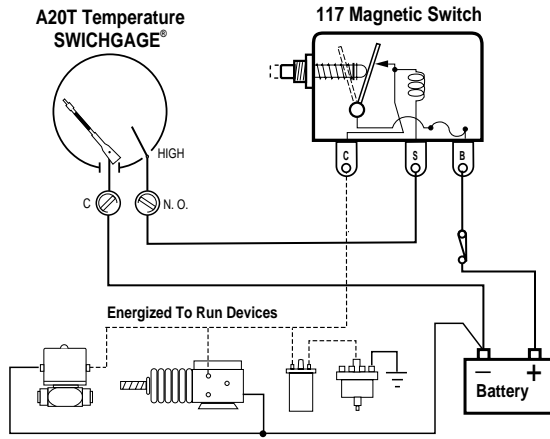

Pre-Alarm Using A20/A25TABS

The A20TABS and A25TABS features a standard limit contact for equipment shutdown on high temperature. It also has an internal SPDT snap-switch to signal an alarm before shutting down. When the snap-switch trips (preset point), on rising temperature, the switch completes a circuit to activate an alarm. If the temperature continues to increase, the face-adjustable pointer contact will make

and the shutdown circuit will be completed (see the typical diagram below for reference). The front contact shutdown limit setting (which is adjustable) and the snap-switch are preset at the factory. Refer to "Temperature Ranges and Factory Settings" table on opposite page for settings. For alternative alarm before shutdown, see Magnetic Switch model 760A or 761APH.

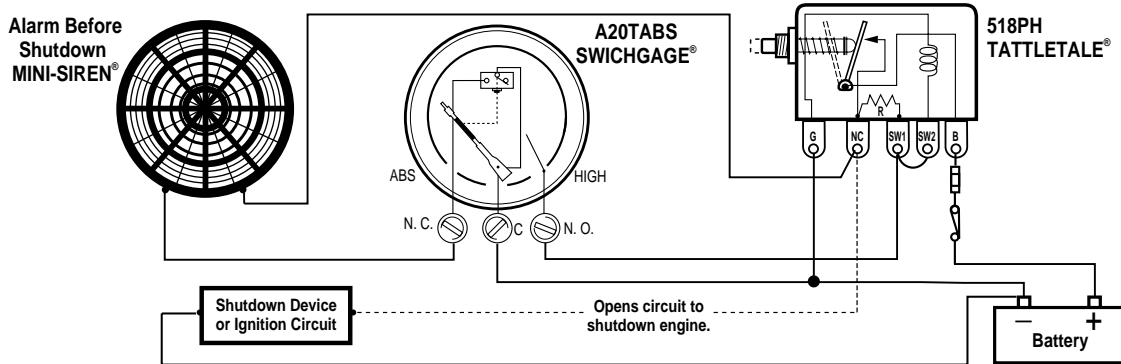

Typical Internal Wiring Diagrams

Pointer shown in the shelf position. Pointer type contact rating: pilot-duty 2 A @ 30 VAC/VDC resistive.
Snap-acting switch rating: 3 A @ 30 VDC inductive. 4 A @ 125 VAC inductive.

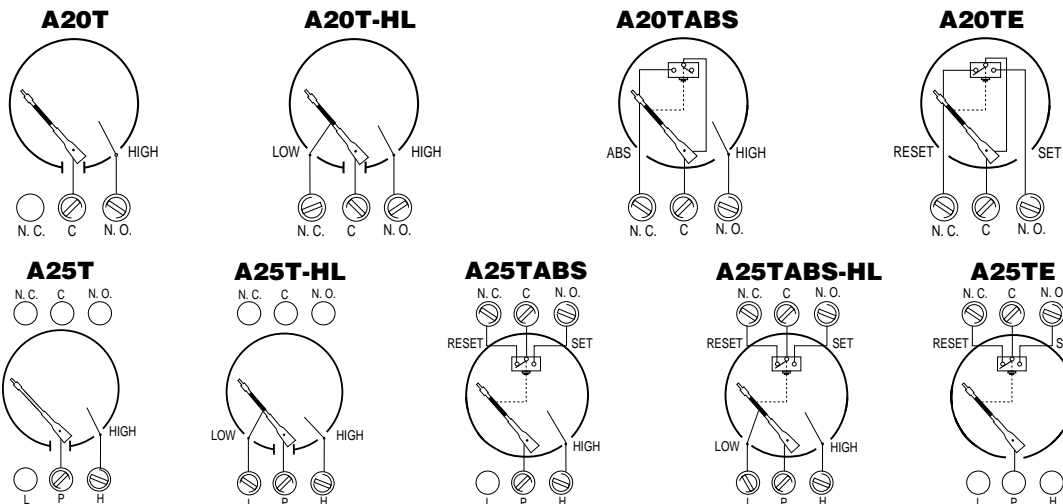

How to Order

To order, use the diagram below. List options in ascending alphabetical order (A-Z). Example: **A20T-B1-250-4**.

Base Model

A20T	A20TG
A20TL	A25T
A20TO	A25TL
A20TE	A25TE
A20TABS	A25TABS
A20TB	A25TH
A20TH	A25TG

Options[†]

- B1** = Black bezel
- EX** = Explosion-proof (CSA Listed for Class I, Div. 1, Groups C & D)*
- EL** = Explosion-proof less case
- HL** = High and low contacts
- K** = Knob adjusting face contact
- OS** = Oil sealed (Silicone Oil)
- UA** = Temperature bulb style "A" (10-05-0166)
- UB** = Temperature bulb style "B" (10-01-0061)
- UC** = Temperature bulb style "C" (10-01-0060)
- UD** = Temperature bulb style "D" (10-00-0286)
- UE** = Temperature bulb style "E" (10-01-0084)
- UF** = Temperature bulb style "F" (10-00-0577)
- UG** = Temperature bulb style "G" (10-00-0578)
- UH** = Temperature bulb style "H" (10-00-2466)
- UJ** = Temperature bulb style J (10051153)
- UK** = Temperature bulb style K (10054886)

[†]Options not available on all models or configurations.
^{*}A25TE-EX only is CSA listed for hazardous locations.
^{**}This option is not covered by the CE mark.

Temperature Capillary Armor Type and Length

Capillary Armor Type

Blank = PVC armor, copper capillary
S = Stainless steel armor, copper capillary

Capillary Length (specify after capillary type; example: "S4")

4 = 4 ft. (1.2 m)

Specify other length = Available in 2 ft. increments thru 20 ft.; 5 ft. increments above 20 ft. (0.5 m. increments from 1.5–10 m.; 2 m. increments thru 34 m. **Specify "M" following length, i.e. 1.5M.**)

Range^{††}

Dual scale (°F/°C)		Single scale (°C)		
°F	°C			
120	= 32-120	0-49	70C	= 0-70°C
160	= 32-160	0-71	100C	= 45-100°C
220	= 130-220	54-104	120C	= 50-120°C
250	= 130-250	60-121	140C	= 60-140°C
300	= 140-300	60-149	160C	= 70-160°C
320	= 160-320	71-160		
350	= 180-350	82-177		
440	= 300-440	149-227		

^{††}Consult factory for availability of dials other than °F/°C. Select scale so your normal operating temperature is in the upper half of the scale.

Illumination – Order Separately

A20 Series: Clamp Lite Assembly; 12 V= 05702176; 24 V= 05702177

A25 Series: N/A.



Warranty

A two-year warranty on materials and workmanship is given with this FWMurphy product. A copy of the warranty may be viewed or printed by going to www.fwmurphy.com/warranty.asp.