

# 20 and 25 Series Pressure SWICHGAGE®



## 2 and 2-1/2 in. (51 and 64 mm) Dial

- Combination Indicating Gage and Limit Switch
- Critical Pressure Limit Switch Is Visible and Adjustable (Most Models)
- Switch Can Activate Alarms and/or Shutdown Equipment
- Exceeds SAE Standards

## Description

The 20 Series (2 inch/51 mm dial) and the 25 Series (2-1/2 inch/64 mm dial) SWICHGAGE® models are diaphragm-actuated, pressure-indicating gages, with built-in electrical switches. These switches are used for tripping alarms and/or shutdown devices.

Ranges are available from 0-15 psi (103 kPa) [1.0 bar] thru 0-400 psi (2.8 MPa) [28 bar].

The gage mechanism is enclosed in a steel case coated to resist corrosion. A polycarbonate, break-resistant lens and a polished, stainless steel bezel help protect this rugged, built-to-last instrument.

Accuracy and protection from moderate overpressure is assured by a unique, unitized diaphragm chamber. A built-in pulsation dampener helps eliminate pointer flutter and is removable for cleaning.

For models 20P and 25P, the gage pointer acts as a pressure indicator and as one switch pole which completes a circuit when it touches the adjustable limit contact. Contacts are grounded through the SWICHGAGE® case and have self-cleaning motion to ensure electrical continuity.

Models 20PE and 25PE have internal snap-acting SPDT switches.

Gage-only models, without the switches (MURPHYGAGE®) are also available.

## Applications

The SWICHGAGE® was specifically designed to protect engines/equipment in Oil Field, Marine, Irrigation, Construction and Trucking applications to monitor Engine Lube Pressure, Water Pump Pressure, Hydraulic Pressure, Air Pressure, etc.

## Specifications

**Dial:** White on black, dual scale; U.S.A. standard scale is psi/kPa; U.K. standard scale is psi/bar; others available (see How to Order).

CE\*\*

**Case:** Plated steel; mounting clamp included (except for direct mount models).

**Bezel:** Polished stainless steel, standard; others are available (see How to Order).

**Lens:** Polycarbonate, high-impact.

**Oil:** Silicon Oil.

### Temperature Range:

Ambient: -40°F (-40°C) thru 150°F (66°C).

Process: -40°F (-40°C) thru 250°F (121°C).

**Process Connection:** 1/8-27 NPTM brass.

**Sensing Element:** Beryllium copper diaphragm.

### Gage Accuracy (% of Full Scale):

RANGE	LOWER 1/4	MIDDLE 1/2	UPPER 1/4
≤300 psi (20 Bar)	±3%	±2%	±3%
400 psi (28 Bar)	±3%	±3%	±5%

**Maximum Pressure:** See Pressure Ranges and Factory Settings table on page 2.

### Adjustable Limit Contact (20P and 25P):

SPST contact; pilot-duty only, 2 A @ 30 VAC/DC;

Normally Close (NC) when the low limit is met.

Normally Open (NO) when pointer is in normal operating range. Contacts are gold flashed silver.

Limit Contact Adjustment: *by a 1/16 in. hex wrench thru 100% of the scale.*

Limit Contact Wire Leads: *18 AWG (1.0 mm<sup>2</sup>) x 12 in. (305 mm).*

### Snap-Switch Rating (20PE and 25PE):

SPDT, 3 A @ 30 VDC inductive; 4 A @ 125 VAC inductive.

Snap-Switch Wire Leads: *20 AWG (0.75 mm<sup>2</sup>) x 12 in. (305 mm).*

**Unit Weight:** 20 Series: 8 oz. (0.23 kg).

25 Series Models: 11 oz. (0.31 kg).

**Unit Dimensions:** 20 Series: 3 x 3 x 3 in. (76 x 76 x 76 mm). 25 Series Models: 4-3/4 x 4-3/4 x 2-3/4 in. (121 x 121 x 70 mm).

## Base Models

### 20P and 25P Series SWICHGAGE®

The gage pointer makes with an adjustable contact to complete a pilot-duty circuit.

### 20PE and 25PE SWICHGAGE®

20PE (was 20EO) and 25PE (was 25EO).

Features internal snap-acting SPDT switches, instead of the single pole/pointer contacts. When the switch closes on falling pressure, it becomes Set, as pressure rises the switch Resets.

### 20PABS and 25PABS SWICHGAGE®

Same as 20P and 25P with internal SPDT snap-switch for pre-alarm.

### 20P7 and 25P7 Lockout SWICHGAGE®

Same as 20P and 25P Series. They also include a front, semi-automatic lockout for startup override. This built-in device holds the pointer away from the contact on startup. When pressure exceeds the set point, the lockout is automatically disengaged (see page 3 for details).

### 20PG and 25PG MURPHYGAGE®

Gage without contact(s).

## Warranty

A two-year limited warranty on materials and workmanship is given with this Murphy product. Details are available on request and are packed with each unit.

\*\*Products covered by this bulletin comply with EMC Council directive 89/336/EEC regarding electromagnetic compatibility except as noted.

## Dimensions

### 20 Series Models

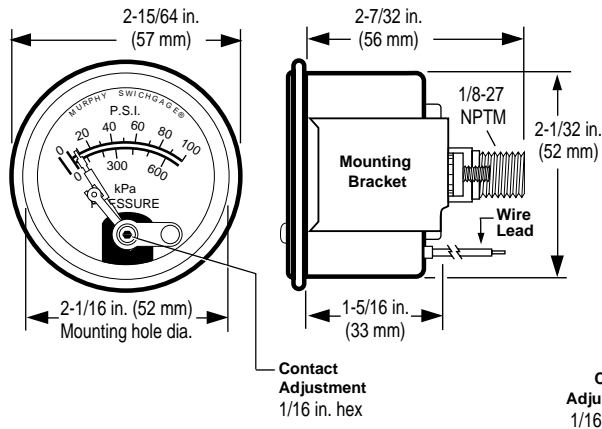

### 25 Series Models

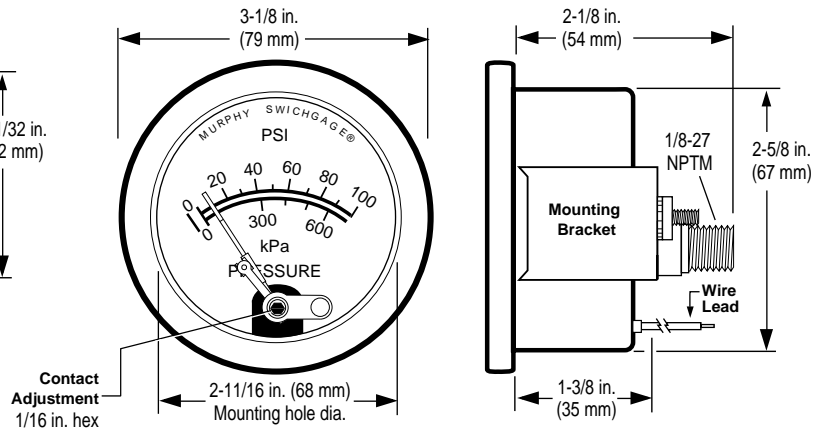

## Pressure Ranges and Factory Settings

### NOTES

- Values in ( ) are mathematical conversions from psi to kPa/MPa—they do not reflect actual second scale range. U.S.A. standard scale is psi/kPa; U.K. standard scale is psi/bar—exact set-point shown. Consult factory for other scales.
- For models 20PE and 25PE; the switch trip point cannot be set at either the low or high extreme of the scale. The trip point must allow for the reset differential.
- For adjustable switch models, the trip point is adjustable **only** over the lower half of the scale.

Ranges Available psi (kPa) [bar]	Maximum Pressure	Standard Settings			High Settings*			20PABS and 25PABS Settings					
		psi	(kPa)	[bar]	psi	(kPa)	[bar]	Low			Alarm†		
0-15 (103) [1.0]	2 x scale	3	(21)	[0.2]	12	(83)	[0.8]	3	(21)	[0.2]	6	(41)	[0.3]
0-30 (207) [2.0]	2 x scale	7	(48)	[0.4]	24	(165)	[1.6]	7	(48)	[0.4]	10	(69)	[0.6]
0-50 (345) [3.5]	2 x scale	10	(69)	[0.8]	40	(276)	[2.8]	10	(69)	[0.8]	13	(90)	[1.0]
0-75 (517) [5.0]	2 x scale	15	(103)	[1.0]	60	(414)	[4.0]	15	(103)	[1.0]	18	(124)	[1.5]
0-100 (690) [7.0]	2 x scale	20	(138)	[1.5]	80	(552)	[5.5]	20	(138)	[1.0]	23	(159)	[1.5]
0-150 (1.0 MPa) [10]	2 x scale	30	(207)	[2.0]	120	(827)	[8.0]	30	(207)	[1.5]	33	(228)	[2.0]
0-200 (1.4 MPa) [14]	2 x scale	50	(345)	[3.0]	150	(1 MPa) [10]		50	(345)	[3.0]	53	(365)	[4.0]
0-300 (2.1 MPa) [20]	1-2/3 x scale	75	(517)	[5.0]	225	(1.6 MPa) [15]		75	(517)	[5.0]	78	(538)	[5.0]
0-400 (2.8 MPa) [28]	1-1/4 x scale	150	(1.0 MPa) [7.0]		300	(2.1 MPa) [20]		75	(517)	[5.0]	150	(1 MPa) [10]	

\*Low settings for Hi/Lo option same as standard settings. Hi/Lo option available for 20P and 25P models only.

†SPDT Snap-switch is the alarm switch.

## The Inside Story

- Process Connection and Port:** Machined from brass bar stock. Together with the diaphragm forms the diaphragm chamber.
- Diaphragm:** Beryllium copper; material is die formed and heat treated to very close physical and metallurgical specifications.
- Pulsation Dampener:** Designed to minimize undesirable pointer chatter. It is removable for cleaning.
- Dial:** White letters on a black background, dual scale (psi & kPa) standard; others available on request (see How to Order on page 4).
- Case:** Steel with zinc and iridite; mounting clamp included (except for direct mount models).
- Bezel:** Polished stainless steel standard, black bezel also available.
- Lens:** Made of polycarbonate glass, high-impact treated.
- Pointer:** Tempered nickel silver for continuity and corrosion resistance. It is mounted on a machined brass post.
- Limit Contact:** SPST contact; N.C. when low limit is met. N.O. when pointer operates above limit.
- Limit Contact Adjustment:** by 1/16 in. hex type wrench thru 100% of the scale. Easy adjustment knob available.
- Wire Leads:** 12 in. (305 mm) long, 18 AWG (1.0 mm<sup>2</sup>) for face-adjustable contacts. 20 AWG (0.75 mm<sup>2</sup>) for Snap-switches models.

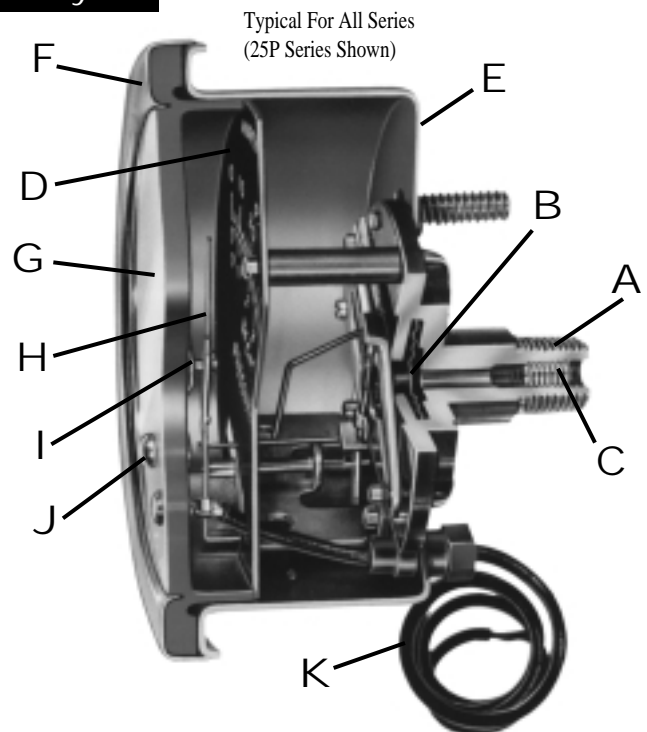

## Magnetic Switch

**INDUCTIVE AND HIGH CURRENT LOADS REQUIRE THE USE OF A MAGNETIC SWITCH.** The SWICHGAGE® contacts are for light-duty electrical switching to operate alarms or control devices. Murphy manufactures the Magnetic Switch for protection of the light-duty SWICHGAGE® limit contacts.

TATTLETALE® Magnetic Switches show the cause of shutdown for applications that include: capacitor discharge or magneto ignitions, battery systems and electric motor driven equipment. Typical wiring diagrams are shown below.

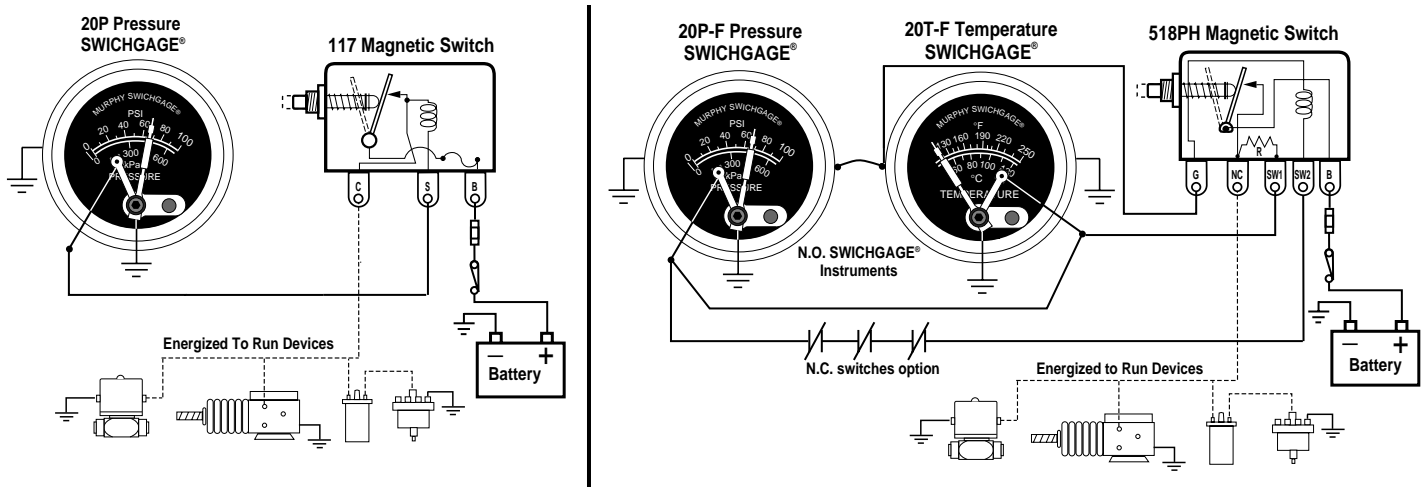

## Start-Up Lockout

The SWICHGAGE® low limit contact can be by-passed on start-up by pushing this optional lockout button. It holds the pointer away from the shutdown contact while the engine starts. The lockout will disengage automatically on rising pressure.

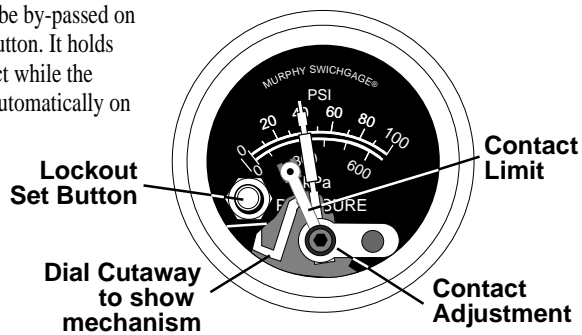

## Pre-Alarm Using 20/25PABS

The 20PABS and 25PABS features a standard limit contact for low pressure equipment shutdown. It also has an internal SPDT snap-switch to signal an alarm before shutting down. When the low side of the snap-switch trips (preset point), on falling pressure, the switch completes a circuit to activate an alarm. If the pressure continues to fall, the face-adjustable pointer contact will make and the

shutdown circuit will be completed (see the typical diagram below for reference). The front contact shutdown limit setting (which is adjustable) and the snap-switch are preset at the factory. Refer to "Pressure Ranges and Factory Settings" table on opposite page for settings. For alternative alarm before shutdown, see Magnetic Switch model 760A or 761APH.

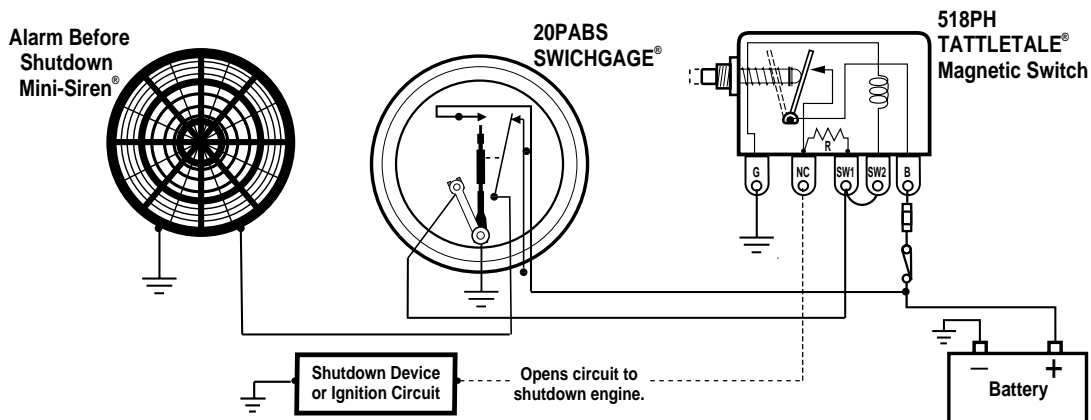

# How to Order

To order, use the diagram below. List options in ascending alphabetical order (A-Z). Example: **20P-IP1-100**.

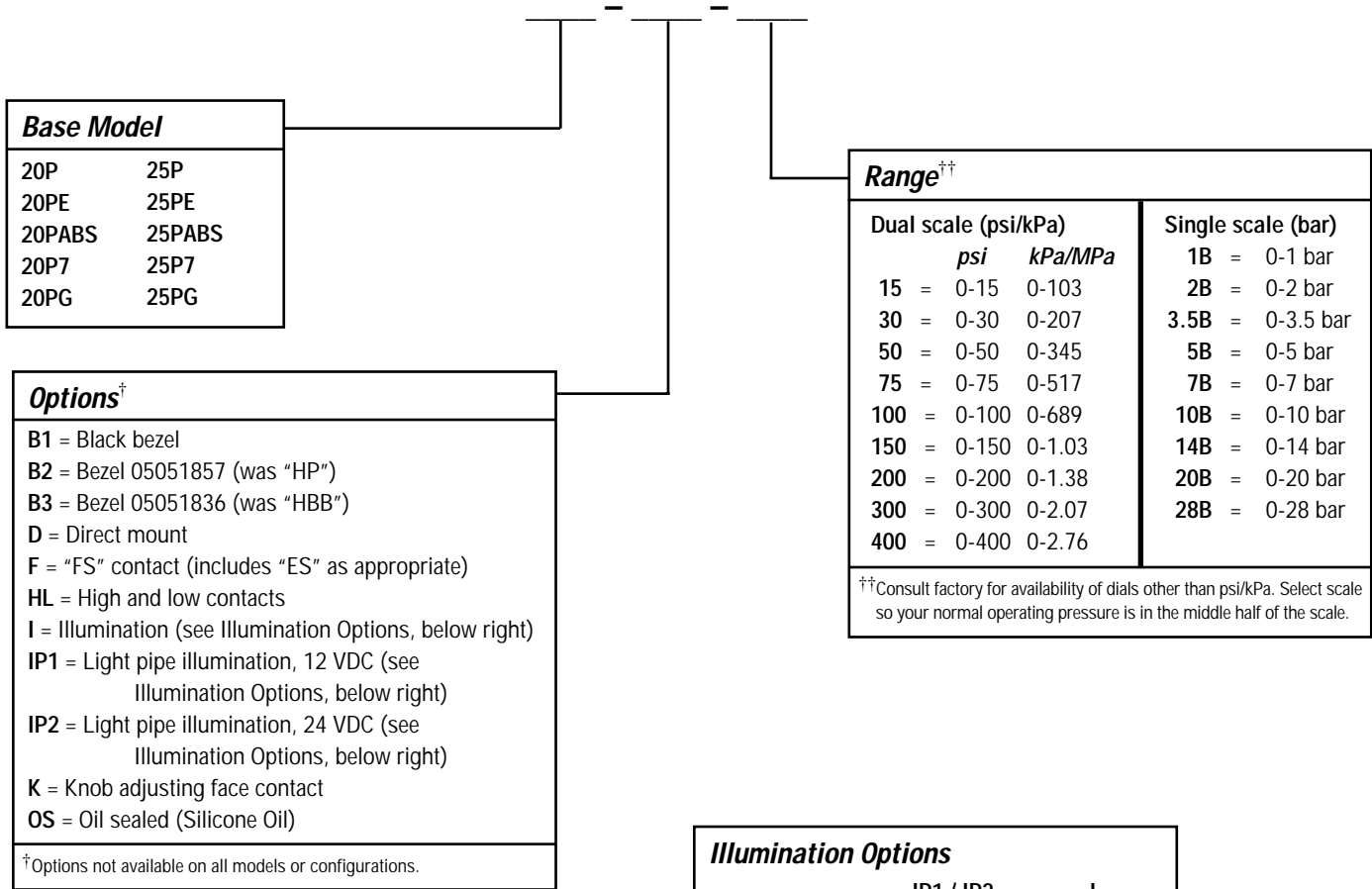

<b>Illumination Options</b>		
	IP1 / IP2	I
20 Series	x	x <sup>1</sup>
25 Series	N/A	x <sup>2</sup>

<sup>1</sup>Can be used with standard Clamp Lite Assembly (12 V= 05702176; 24 V= 05702177).  
<sup>2</sup>Order Lamp and Socket Assembly separately. (12 V= 05010198; 24 V= 05010199).