

4-1/2 in. (114 mm) Dial Pressure SWICHGAGE® To Disable Magneto, CD and Battery Ignition Systems

45-96003B
Revised 03-03
Catalog Section 05
(00-02-0770)

FWMurphy



45 Series

- Combination Pressure SWICHGAGE® and Built-in Electromagnetic Switch
- High and Low Contacts Can Disable Engine's Ignition Due to Critical Pressure
- Magnetic Switch Will Not Allow Engine Restart Due to Flywheel Inertia
- Semi-Automatic Low Pressure Override Push Button for Engine Startup

Description

Murphy's 45 Series pressure SWICHGAGE® incorporates a built-in electromagnetic switch to disable an ignition whenever the gage contacts operate.

Flywheel inertia cannot restart the engine since the electromagnetic switch will not allow the ignition to operate until manually reset.

A semi-automatic lockout push button overrides the low pressure contact for equipment startup. The lockout automatically disengages when pressure is established allowing the low limit contact to be armed for operation should a low pressure condition occur.

Models are available for conventional magnetos, capacitor discharge (CD) ignitions, 12/32 VDC battery systems, and 120 VAC power sources.

Ranges are available from 30" vac (-101 kPa) [-1.01 bar] thru 10,000 psi (138 MPa) [1379 bar].

Applications

Recommended for most field gathering pumps, the 45 Series instantly stops your pump when pressures drop due to line breaks, leaks or when your tank is pumped out. Overpressure shutdown can occur due to closure of valves in the line, or other line restrictions.

Specifications

Dial: White on black, dual scale, psi and kPa standard, 4-1/2 in. (114 mm) diameter.

Case: Die cast aluminum.

Process Connection:

1/4 NPT thru 1000 psi (6.9 MPa) [69 bar];
1/2 NPT 1500 psi (10 MPa) [103 bar] thru
10,000 psi (138 MPa) [1379 bar].

Overrange: Do not exceed 10% above full range.

Sensing Element: Select from bronze or 316 stainless steel bourdon tube.

Gage Accuracy: $\pm 2\%$ for first and last quarters of scale; the middle half is $\pm 1\%$.

Pressure Relief Disc: Located in rear of case.

Contact Ratings:

45B = 12/30 VDC coil; 10 A, 32 VD DC contacts
45CD = CD ignition coil; 10 A contacts
45M = Magneto ign. coil; 10 A contacts
45N = 120 VAC coil; 10 A, 120 VAC contacts

Wire Connections:

1/2 NPT conduit and terminal block.

Item Weight:

5 lbs 9 oz (2.5 kg) approximately.

Item Dimensions:

10 x 9 x 6 in. (254 x 229 x 152 mm).

Basic Models

45B Series SWICHGAGE®

For use with 12-32 VDC battery ignition systems; it includes battery ignition type magnetic switch.

45CD Series SWICHGAGE®

For use with (CD) capacitor discharge ignitions; it includes CD ignition type magnetic switch.

45M Series SWICHGAGE®

For use with magneto type ignitions; it includes magneto ignition type magnetic switch.

45N Series SWICHGAGE®

For specific use with 110 VAC Power Sources; it includes 120 VAC type magnetic switch.

Dimensions

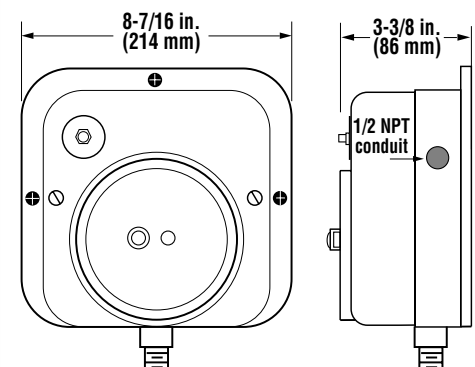

How to Order

Specify model number. **NOTE:** No designator is required for **Standard** configurations.
List options in alphabetical order (A to Z). Place a dash (-) between each option. See example below.

45B - S - 60 -

Base Model

45B
45CD
45M
45N

Bourdon Tube/Socket

A = Bronze/Brass (std. <=1,000 psi)
S = Stainless Steel/Stainless Steel

Options (NOTE: Not all options available for every model.)

BC = Back connected bourdon tube
LC = Less case
P4 = PT147 Pressure transmitter w/ 5ft. capillary*
P4L = PT147 less pulsation dampener 5ft. capillary*
*For capillary greater than 5 ft., specify in 5 ft., increments following designator, example: P4I5
P6 = PT167 pressure transmitter direct mount
T1 = Tamperproof knob locks

45 Series Typical Wiring Diagram

Shown with CD Ignition
type magnetic switch

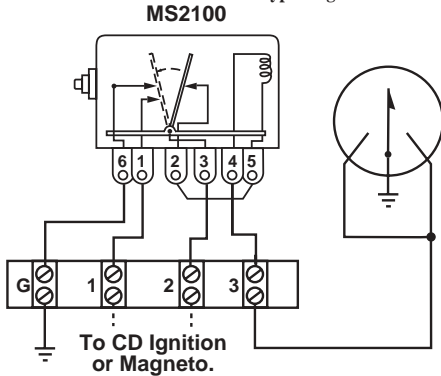

Contact Rating: 12/32 VDC coil, 10 A 32 VDC battery ignition contacts;
Magneto ignition coil, 10 A magneto ignitions contacts; CD ignition coil, 10 A
CD ignition contacts; 120 VAC coil, 10 A, 120 VAC contacts.

Range

Code	Vacuum/psi	kPa/MPa	bar
30HV60H	30" Hg/Vac - 60" Hg/Press.	-101 kPa-203 kPa	-1.01-2.03
30V	30" vac - 0 psi	-101 kPa-0 kPa	-1.01 - 0
30V15	30" vac - 15 psi	-101 kPa-103 kPa	-1.01 - 1.03
30V30	30" vac - 30 ps	-101 kPa-207 kPa	-1.01 - 2.07
30V100	30" vac - 100 psi	-101 kPa-689 kPa	-1.01 - 6.89
30V200	30" vac - 200 psi	-101 kPa-1.38 MPa	-1.01 - 13.79
30V300	30" vac - 300 psi	-101 kPa-2.03 MPa	-1.01 - 20.68
15	15 psi	0 - 103 kPa	0 - 1.03
30	0 - 30 psi	0 - 207 kPa	0 - 2.06
60	0 - 60 psi	0 - 414 kPa	0 - 4.13
100	0 - 100 psi	0 - 689 kPa	0 - 6.89
160	0 - 160 psi	0 - 1.10 MPa	0 - 11.03
200	0 - 200 psi	0 - 1.38 MPa	0 - 13.78
300	0 - 300 psi	0 - 2.07 MPa	0 - 20.68
400	0 - 400 psi	0 - 2.76 MPa	0 - 27.57
600	0 - 600 psi	0 - 4.14 MPa	0 - 41.36
1000	0 - 1000 psi	0 - 6.89 MPa	0 - 68.95
1500	0 - 1500 psi	0 - 10.34 MPa	0 - 103.42
2000	0 - 2000 psi	0 - 13.79 MPa	0 - 137.89
3000	0 - 3000 psi	0 - 20.68 MPa	0 - 206.84
5000	0 - 5000 psi	0 - 34.48 MPa	0 - 344.73
10000	0 - 10,000 psi	0 - 68.95 MPa	0 - 689.47

Dials

Dials are dual scaled psi and kPa/MPa. Single scale and custom dials are available.

Warranty

A two-year limited warranty on materials and workmanship is given with this Murphy product. Details are available on request and are packed with each unit.